



⚠ WARNING



Read Owner's Manual for complete instructions and warnings.

This quick guide is not a substitute for reading and understanding all instruction manuals and warning labels supplied with the equipment. Manuals are available at magnum.graco.com



Follow pressure relief procedure and wear protective equipment including but not limited to protective eye wear.



SKIN INJECTION HAZARD: Keep clear of spray tip and leaks. Engage trigger lock when not spraying.



FIRE AND EXPLOSION HAZARD: Follow fire and explosion warnings as listed in your manual.

FAILURE TO FOLLOW ALL WARNINGS CAN RESULT IN SERIOUS INJURY, AMPUTATION, OR DEATH.

SETUP

- 1 Connect hose to gun. Remove red cap, connect hose to sprayer. Securely tighten.

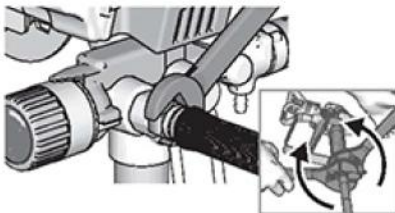

- 2 Turn gun trigger lock to locked position. Unthread spray tip and guard assembly.

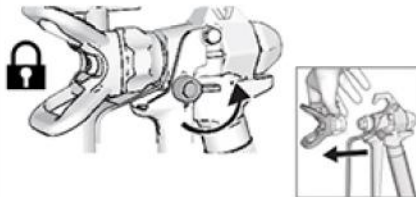

- 3 Turn Pressure Control Knob to lowest setting.



START UP – FLUSHING

- 1 Turn Power Switch **OFF** and plug sprayer into grounded outlet.



- 2 Separate small, clear drain tube from large suction tube and place into waste pail.

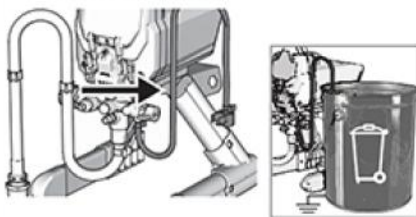

- 3 Submerge suction tube in water if spraying water-based material or flushing fluid if spraying oil-based.



- 4 With the Prime/Spray Valve down to **PRIME**, press PushPrime™ button twice, turn Pressure Control Knob to Prime/Clean setting. Turn Power Switch **ON**.

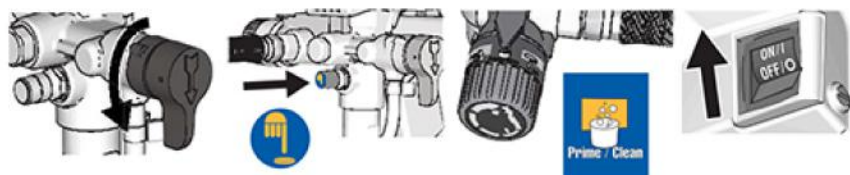

- 5 Allow fluid to flow out drain tube for 30-60 seconds. Turn Power Switch **OFF**.



START UP – FILL PUMP, GUN & HOSE WITH PAINT

- ① Submerge suction tube in paint. Turn Power Switch **ON** and wait to see paint coming into the drain tube. Turn Power Switch **OFF**.

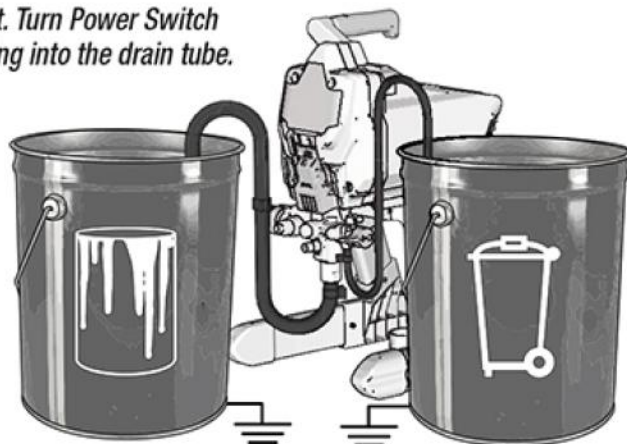

- ② Trigger gun into waste pail, turn Prime/Spray Valve forward to **SPRAY** and turn Power Switch **ON**.

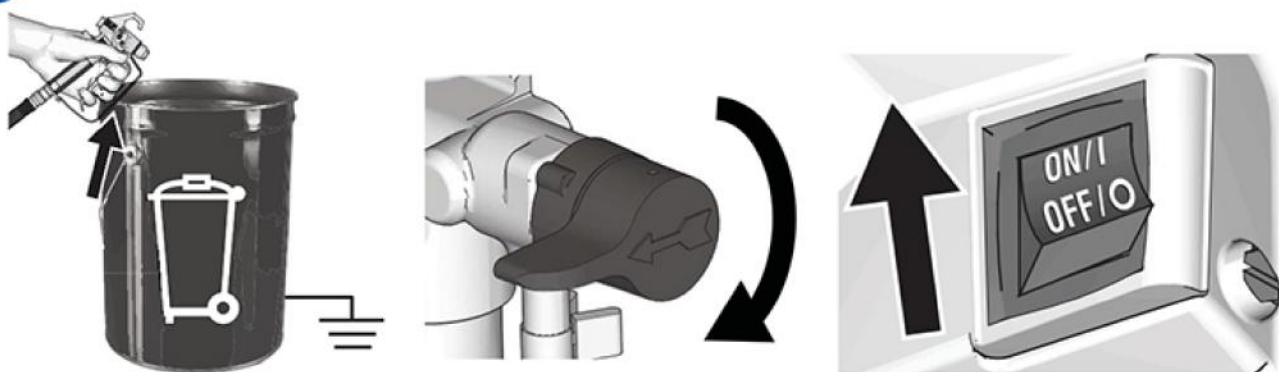

- ③ When paint comes out of the gun, release trigger. Turn gun trigger lock to locked position. Thread spray tip and guard assembly to gun.

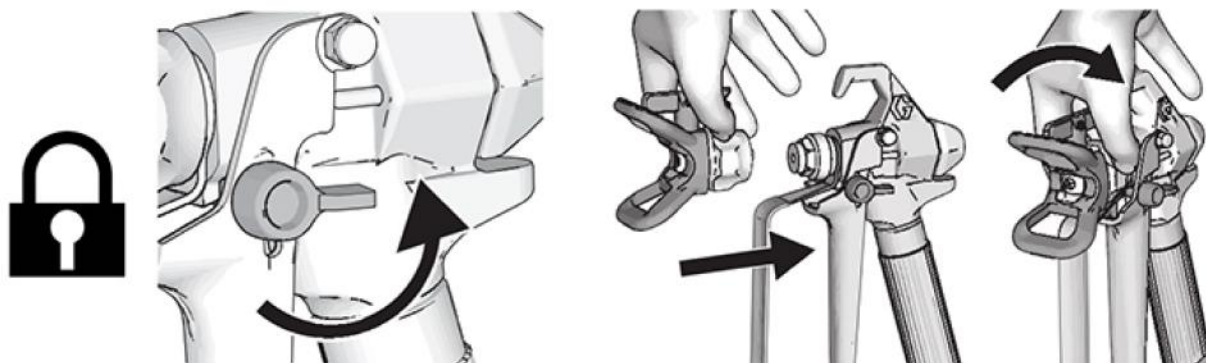

- ④ Attach drain tube to suction tube and turn Pressure Control Knob to Spray Setting. Start at lowest setting and increase until pattern is evenly distributed, no gaps at edge.



3000 psi
207 bar/20.7 MPa

1500 psi
103 bar/10.3 MPa

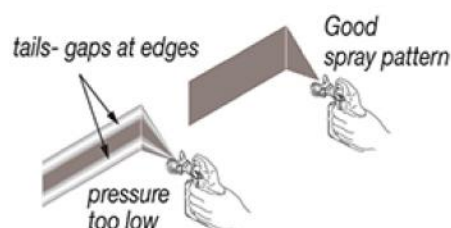

YOU ARE NOW READY TO SPRAY!

CLEAN UP: WATER-BASED PAINTS (see Owner's Manual for oil-based paints)

- ① Turn Power Switch **OFF**. Place suction and drain tubes in waste pail. Turn Prime/Spray Valve down to **PRIME**. Turn Pressure Control Knob to Prime/Clean setting. Trigger gun into waste pail.



- ② With the trigger lock in locked position, unthread spray tip and guard assembly from gun. Place in waste pail for further cleaning.

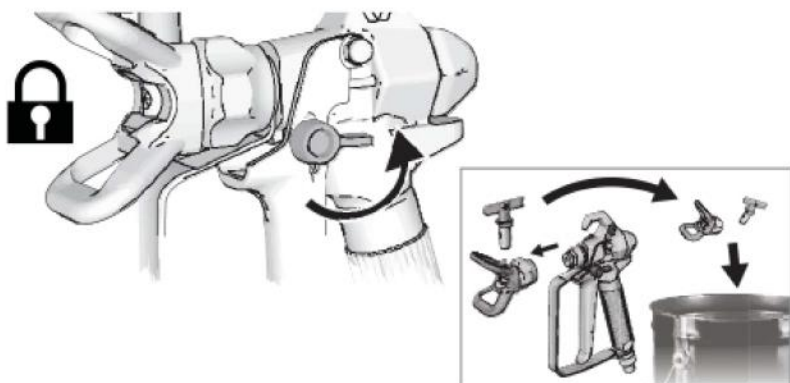

- ③ Thread Power Flush™ attachment onto garden hose, turn water on. Rinse paint off of suction and drain tubes, inlet screen and spray tip/guard.

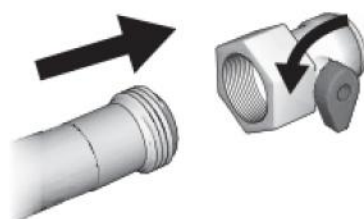

- ④ Unscrew inlet strainer from suction tube and place in waste pail for cleaning. Thread Power Flush attachment to suction tube. Turn Power Switch **ON** and let water run through drain tube for 20 seconds. Turn Power Switch **OFF**.

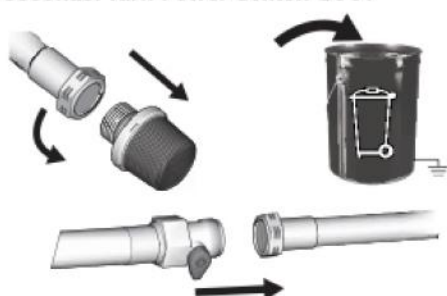

- ⑤ **TO SAVE PAINT IN HOSE:** Trigger gun into paint pail, turn Prime/Spray Valve forward to **SPRAY** and turn Power Switch **ON**. When water comes out of gun, keep gun triggered and aim into waste pail. Continue to flush until water runs clear.

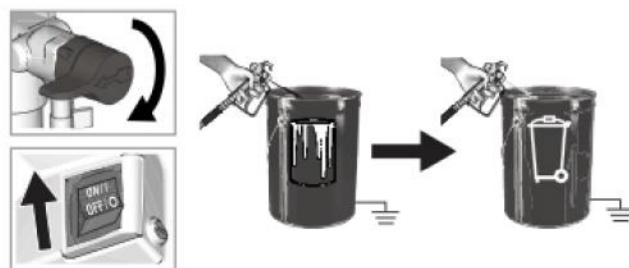

- ⑥ Turn Pressure Control Knob to lowest setting and release trigger. Turn gun trigger lock to locked position. Turn Prime/Spray Valve down to **PRIME**. Turn Power Switch **OFF**.

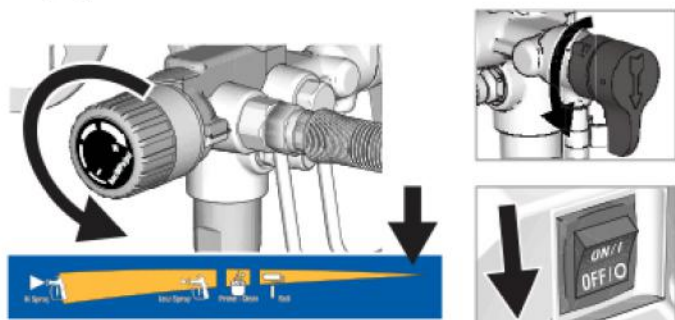

- ⑦ Clean spray tip, guard, inlet strainer with brush. Remove gun filter and clean. Reassemble gun filter, spray tip and guard.

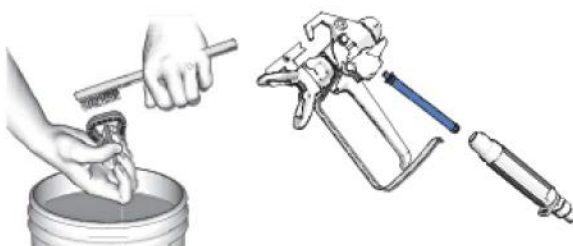

STORAGE FLUID

- ① Remove Power Flush attachment from suction tube. Submerge suction tube in Pump Armor.™

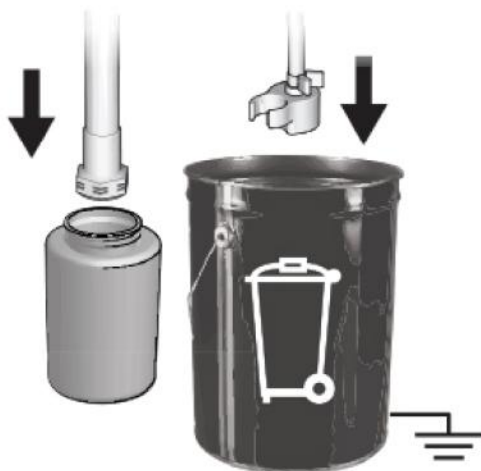

- ② Turn Prime/Spray Valve down to **PRIME**. Turn Power Switch **ON**. Turn Pressure Control Knob to Prime/Clean setting.



- ③ When Pump Armor comes out of drain tube, turn Pressure Control Knob to lowest setting and Power Switch **OFF**.

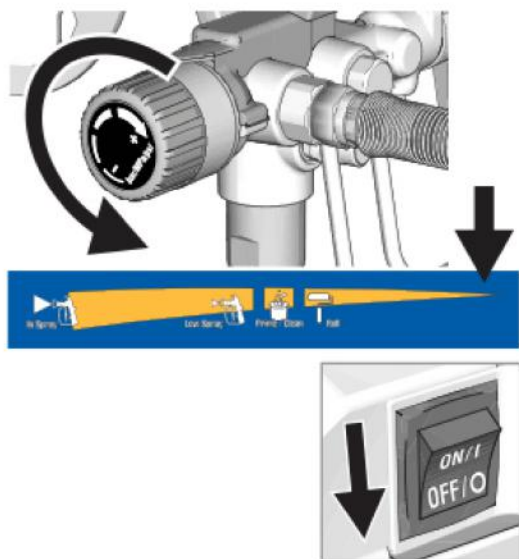

- ④ Turn Prime/Spray Valve to **SPRAY** and install inlet strainer on suction tube for storage.

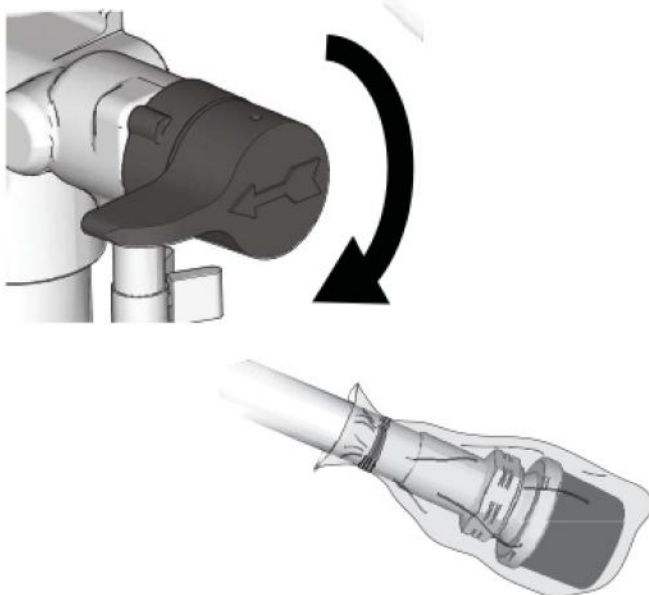

Every Graco purchase comes with **A+ Customer Service.**

Questions?

(888) 541-9788

magnum.graco.com/aplus

Scan QR code for Operational Video



magnum.graco.com/magop