

## GMAX™ 3400, GMAX™ II 3900/5900/7900, and 5900 HD/7900 HD Airless Sprayers

3A6417L

EN

**For the application of architectural paints and coatings. For professional use only. Not approved for use in European explosive atmosphere locations.**

3300 psi (22.8 MPa, 228 bar) Maximum Working Pressure



### Important Safety Instructions

For complete warnings refer to the GMAX Operation manual.

#### Related Manuals:

3A6400 GMAX Operation

This manual contains parts lists for the following sprayers:

Model	Standard	ProContractor	Lo-Boy	Ironman
GMAX 3400	17E825			
GMAX II 3900	17E827, 2012514 (EMEA)		17E826	
GMAX II 5900	17E831		17E829	
GMAX II 5900 Convertible	17E830			
GMAX II 7900	17E836		17E834	
GMAX II 5900 HD	17E839			
GMAX II 7900 HD	17E841			
GMAX 3400	17G997			
GMAX II 3900	17G999, 2012515 (EMEA)	17E828, 2012213 (EMEA)	17G998	
GMAX II 5900	17H810	17E832	17H808	17E833
GMAX II 7900	17H818	17E837	17H817	17E838
GMAX II 7900 Roof Rig				17E835
GMAX II 5900 HD	17H819	17E840		
GMAX II 7900 HD	17H820	17E842		17E843

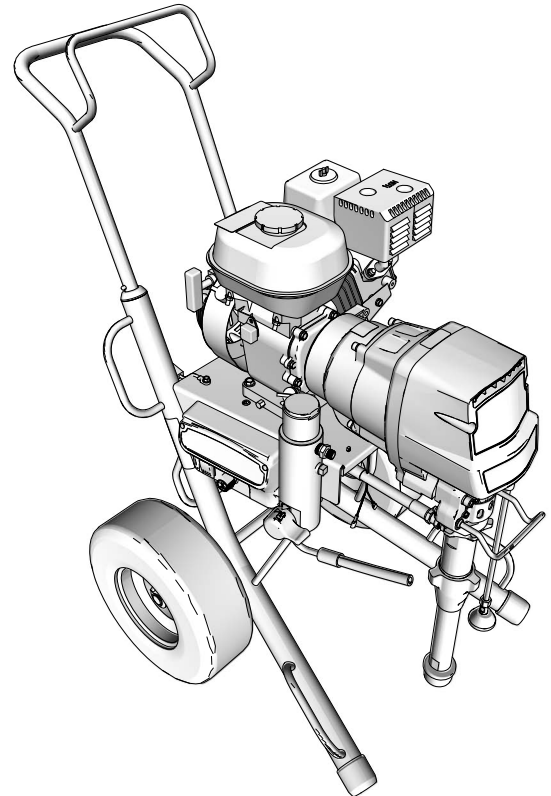

# Contents

<b>GMAX 3400 Standard Series</b> .....	<b>4</b>	<b>GMAX II 7900 and 7900 HD ProContractor Series</b>	<b>28</b>
Parts List - GMAX 3400 Standard Series .....	5	Parts List - GMAX II 7900 and 7900 HD	
<b>GMAX II 3900 Standard Series</b> .....	<b>6</b>	ProContractor Series .....	29
Parts List - GMAX II 3900 Standard Series .....	7	<b>GMAX II 7900 and 7900 HD IronMan Series / Roof</b>	
<b>GMAX II 3900 Lo-Boy Series</b> .....	<b>8</b>	<b>Rig</b> .....	<b>30</b>
Parts List - GMAX II 3900 Lo-Boy Series .....	9	Parts List - GMAX II 7900 and 7900 HD IronMan	
<b>GMAX II 3900 ProContractor Series</b> .....	<b>10</b>	Series / Roof Rig .....	31
Parts List - GMAX II 3900 ProContractor Series	11	<b>GMAX II 7900 Lo-Boy Series</b> .....	<b>32</b>
<b>GMAX II 5900 and 5900 HD Standard Series</b> .....	<b>12</b>	Parts List - GMAX II 7900 Lo-Boy Series .....	33
Parts List - GMAX II 5900 and 5900 HD Standard		<b>LoBoy Suction Set Kits</b> .....	<b>34</b>
Series .....	13	<b>Control Box 25P549 - GMAX 3400</b> .....	<b>35</b>
<b>GMAX II 5900 Lo-Boy Series</b> .....	<b>14</b>	Parts List - Control Box 25P549 .....	35
Parts List - GMAX II 5900 Lo-Boy Series .....	15	<b>Control Box 16X822 - Standard &amp; Lo-Boy Series</b>	<b>36</b>
<b>GMAX II 5900 and 5900 HD ProContractor Series</b>	<b>16</b>	Parts List - Control Box 16X822 .....	37
Parts List - GMAX II 5900 and 5900 HD		<b>Control Box 16X821 - ProContractor &amp; Ironman</b>	
ProContractor Series .....	17	<b>Series</b> .....	<b>38</b>
<b>GMAX II 5900 IronMan Series</b> .....	<b>18</b>	Parts List - Control Box 16X821 .....	39
Parts List - GMAX II 5900 IronMan Series .....	19	<b>Filter</b> .....	<b>40</b>
<b>GMAX II 5900 Convertible Series</b> .....	<b>20</b>	Parts List - Filter .....	40
Parts List - GMAX II 5900 Convertible Series ..	21	<b>Filter (3400 Models only)</b> .....	<b>41</b>
<b>GMAX II 5900 Convertible Series</b> .....	<b>22</b>	Parts List - Filter .....	41
Engine Detail .....	22	<b>QuikReel™ (ProContractor Sprayers)</b> .....	<b>42</b>
Engine Detail - Parts List .....	23	<b>Notes</b> .....	<b>43</b>
Clutch Housing - Parts Drawing and List .....	24	<b>Pressure Control Wiring Diagrams</b> .....	<b>44</b>
<b>Notes</b> .....	<b>25</b>	GMAX 3400 Sprayers .....	44
<b>GMAX II 7900 and 7900 HD Standard Series</b> .....	<b>26</b>	3900/5900/7900 Sprayers .....	45
Parts List - GMAX II 7900 and 7900 HD Standard		<b>Graco Standard Warranty</b> .....	<b>47</b>
Series .....	27	<b>Graco Information</b> .....	<b>48</b>





# Parts List - GMAX 3400 Standard Series

Ref.	Part	Description	Qty	Ref.	Part	Description	Qty
1	108879	ENGINE, gasoline, 4.0 HP	1	64	112395	SCREW, cap, flng hd	1
2	110837	SCREW, flange, hex	2	67	15C871	CAP, leg	2
3	110838	NUT, lock	2	68	100020	WASHER, lock	4
4	246428	PUMP, displacement, st	1	72	237686	WIRE, ground assembly w/clamp	1
5	119789	FITTING, elbow, street, 45°, 1/4 npt	1	73	112798	SCREW, thread forming, hex hd	1
6	287053	ROD, connecting	1	77	25P549	BOX, control, GMAX 3400	1
6a	196750	SPRING, retaining	1	79	116038	WASHER, wave spring	2
7	195150	NUT, jam, pump	1	80	156306	WASHER, flat	2
8	196762	PIN, straight	1	81	113161	SCREW, flange, hex hd	3
9	15C146	HOOK, pail	1	90▲	194126	LABEL, warning	1
10	117501	SCREW, mach, hex washer hd	4	93	241926	HOSE, coupled	1
11	115099	WASHER, garden hose	1	94	17E927	LABEL, brand, GMAX 3400	1
12	15E813	NUT, jam	1	95	15E891	CLIP, retaining	2
13	15B652	WASHER, suction	1	99▲	15F638	LABEL, warning	1
14	103413	O-RING	2	100	114678	BUSHING, strain relief	1
15	15E805	TUBE, intake, 3400	1	101	119569	BUSHING, strain relief	1
16	246385	STRAINER, 7/8-14 unf	1	111▲	290228	LABEL, caution	1
17	276888	CLIP, drain line	1	123	17Y043	GUN, Contractor PC, RAC X	1
18	119426	SCREW, mach, hex washer hd	8	124	240794	HOSE, coupled, 1/4 in. x 50 ft	1
19	287411	FRAME, cart, GMAX 3400 hi	1	135	15F354	FUNNEL, oil (not shown)	1
34	105510*	WASHER, lock, spring (hi-collar)	10	149	17E932	LABEL, series, GMAX, std	1
35	108803	SCREW, hex, socket head	6		17H899	KIT, gauge, 1/4" (not shown)	1
36	183401	KEY, parallel	1	▲	16Y631	LABEL, warning	1
37	193680	COLLAR, shaft	1	▲	16Y632	LABEL, warning	1
38	*	ARMATURE, clutch, 4 in.	1	▲	16Y633	LABEL, warning	1
39	*	HUB, armature	1	▲		CARD, Medical Alert	
40	*	ROTOR, clutch, 4 in.	1		222385	English, French, Spanish	
41	101682*	SCREW, cap, sch	4		17A134	English, Chinese, Spanish	
46	287489	HANDLE, cart	1		17R476	English, Spanish, Portuguese	
48	109032	SCREW, mach, pnh	4	▲ Replacement Danger and Warning Labels, Tags and Cards are available at no cost.			
49	287483	HOUSING, drive, 3400 <i>includes 9, 10, 18 &amp; grease 110293</i>	1	* Included in Clutch Replacement Kit 241109.			
50	287376	HOUSING, pinion, 3400	1	<b>Part Specifications:</b>			
51	15E535	HOUSING, clutch, mach, 3400	1				
52	116074	WASHER, thrust	1				
53	287484	CRANK, GMAX 3400 <i>includes 52, 56, 57</i>	1				
54	244240	HOSE, coupled, <i>includes 55</i>	1				
55	241920	DEFLECTOR, threaded	1				
56	180131	BEARING, thrust	1				
57	107434	BEARING, thrust	1				
59	100214	WASHER, lock	4				
60	108842	SCREW, cap, hex hd	4				
61	119420	WHEEL, pneumatic	2				
62	287487	COVER, front, painted, <i>includes 10</i>	1				

Ref.	Instruction
▲10	Torque to 115-135 in-lb (12.9-15.2 N•m)
▲12	Torque to 70-80 ft-lb (94.9-108.4 N•m)
▲14	Torque to 130-150 in-lb (14.6-16.9 N•m)
▲16	Torque to 17-23 ft-lb (23.0-31.1 N•m)
▲17	Inflate tires to 28-32 psi (1.93-2.21 bar/0.193-0.221 MPa)
▲18	Torque to 25-35 in-lb (2.8-3.9 N•m)
▲19	Torque to 30-35 in-lb (3.3-3.9 N•m)
▲37	Torque to 170-190 in-lb (19.2-21.4 N•m)

# GMAX II 3900 Standard Series

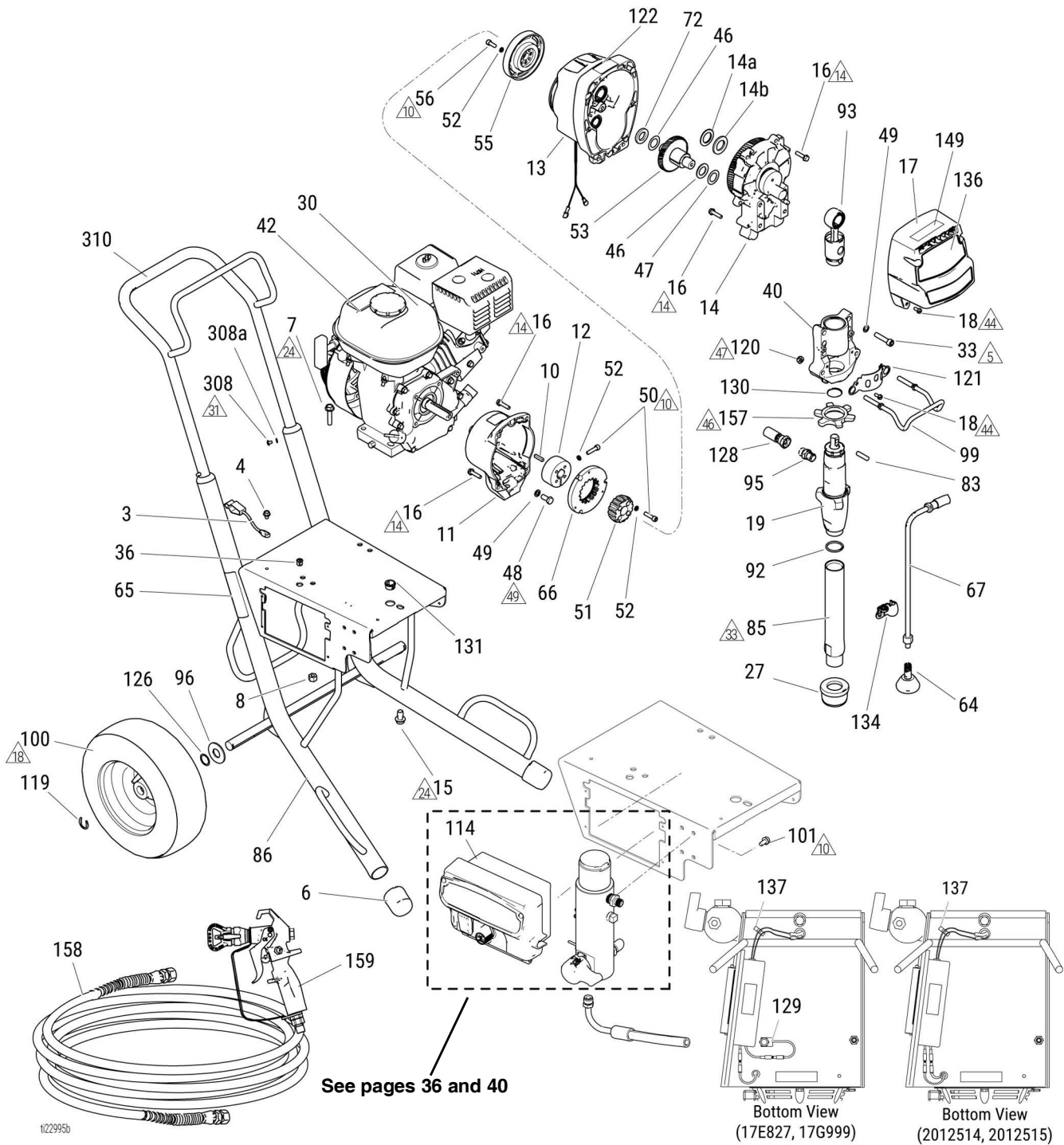

# Parts List - GMAX II 3900 Standard Series

Ref.	Part	Description	Qty.	Ref.	Part	Description	Qty.																								
3	237686	WIRE, ground assembly w/ clamp	1	120★	111040	NUT, lock, insert, nylon	2																								
4	112798	SCREW, thread forming, hex hd	1	121★	16X770	SHIELD, pump rod	1																								
6	15C871	CAP, leg	2	122▲	290228	LABEL, caution	1																								
7	110837	SCREW, flange, hex	2	126	116038	WASHER, wave spring	2																								
8	110838	NUT, lock	2	128	16X909	HOSE, coupled	1																								
10	183401	KEY, parallel	1	129	119579	CONDUCTOR, ground (17E827 only)	1																								
11	15E535	HOUSING, clutch, machine	1	130	119676	SPRING, retaining	1																								
12	193680	COLLAR, shaft	1	131	119569	BUSHING, strain relief	1																								
13	287463	HOUSING, pinion, 3900	1	134★	278204	CLIP, drain line	1																								
14	287467	HOUSING, drive, 3900, <i>includes 14a, 14b</i>	1	135	15F354	FUNNEL, oil (not shown)	1																								
14a	116191	WASHER, thrust	1	136	17E928	LABEL, brand, GMAX 3900	1																								
14b	107089	WASHER, race, thrust	1	137	114687	CLIP, retainer	1																								
15	112395	SCREW, cap, flng hd	1	149	17E933	LABEL, series, GMAX, std	1																								
16	119426	SCREW, mach, hex washer hd	10	157	192723	NUT, retaining	1																								
17	16Y747	COVER, front, (includes 18)	1	158	240794	HOSE, coupled, 1/4 in. x 50 ft	1																								
18★	118444	SCREW, mach, slot hex wash hd	6	159	17Y043	GUN, Contractor PC, RAC X	1																								
19	16Y598	PUMP, displacement, <i>includes 85, 92, 95</i>	1	308	109032	SCREW, mach, pnh	4																								
27	189920	STRAINER, (1-11 1/2 NPSM)	1	308a	100020	WASHER, lock	4																								
30	108879	ENGINE, gasoline, 4.0 HP (17E827, 17G999)	1	310	287489	HANDLE, cart	1																								
	114530	ENGINE, gasoline, 5.5 HP (2012514, 2012515)	1		17H899	KIT, gauge, 1/4" (not shown)	1																								
33	17E917	SCREW, cap, socket head, SST	4	▲	16Y631	LABEL, warning	1																								
36	114678	BUSHING, strain relief	1	▲	16Y632	LABEL, warning	1																								
40★		HOUSING, bearing	1	▲	16Y633	LABEL, warning	1																								
42▲	194126	LABEL, warning	1	▲		CARD, Medical Alert																									
46	114699	WASHER, thrust	2		222385	English, French, Spanish																									
47	114672	WASHER, thrust	1		17A134	English, Chinese, Spanish																									
48	108842	SCREW, cap, hex hd	4		17R476	English, Spanish, Portuguese																									
49★	100214	WASHER, lock	8	▲ Replacement Danger and Warning Labels, Tags and Cards are available at no cost.																											
50†	108803	SCREW, hex, socket head	6	† Included in Clutch Replacement Kit 241109																											
51†		HUB, armature	1	★ Included in Bearing Housing Kit 24V026																											
52†	105510	WASHER, lock, spring (hi-collar)	10	<b>Part Specifications:</b>																											
53	287653	GEAR, combination	1	<table border="1"> <thead> <tr> <th>Ref.</th> <th>Instruction</th> </tr> </thead> <tbody> <tr> <td>▲5</td> <td>Torque to 190-210 in-lb (21.4-23.7 N•m)</td> </tr> <tr> <td>▲10</td> <td>Torque to 115-135 in-lb (12.9-15.2 N•m)</td> </tr> <tr> <td>▲14</td> <td>Torque to 130-150 in-lb (14.6-16.9 N•m)</td> </tr> <tr> <td>▲18</td> <td>Inflate tires to 28-32 psi (1.93-2.21 bar/0.193-0.221 MPa)</td> </tr> <tr> <td>▲24</td> <td>Torque to 17-23 ft-lb (23.0-31.1 N•m)</td> </tr> <tr> <td>▲31</td> <td>Torque to 25-35 in-lb (2.8-3.9 N•m)</td> </tr> <tr> <td>▲33</td> <td>Torque to 70-90 in-lb (7.9-10.1 N•m)</td> </tr> <tr> <td>▲44</td> <td>Torque to 30-35 in-lb (3.3-3.9 N•m)</td> </tr> <tr> <td>▲46</td> <td>Torque to 70-80 ft-lb (94.9-108.4 N•m)</td> </tr> <tr> <td>▲47</td> <td>Torque to 200-230 in-lb (22.5-25.9 N•m)</td> </tr> <tr> <td>▲49</td> <td>Torque to 170-190 in-lb (19.2-21.4 N•m)</td> </tr> </tbody> </table>				Ref.	Instruction	▲5	Torque to 190-210 in-lb (21.4-23.7 N•m)	▲10	Torque to 115-135 in-lb (12.9-15.2 N•m)	▲14	Torque to 130-150 in-lb (14.6-16.9 N•m)	▲18	Inflate tires to 28-32 psi (1.93-2.21 bar/0.193-0.221 MPa)	▲24	Torque to 17-23 ft-lb (23.0-31.1 N•m)	▲31	Torque to 25-35 in-lb (2.8-3.9 N•m)	▲33	Torque to 70-90 in-lb (7.9-10.1 N•m)	▲44	Torque to 30-35 in-lb (3.3-3.9 N•m)	▲46	Torque to 70-80 ft-lb (94.9-108.4 N•m)	▲47	Torque to 200-230 in-lb (22.5-25.9 N•m)	▲49	Torque to 170-190 in-lb (19.2-21.4 N•m)
Ref.	Instruction																														
▲5	Torque to 190-210 in-lb (21.4-23.7 N•m)																														
▲10	Torque to 115-135 in-lb (12.9-15.2 N•m)																														
▲14	Torque to 130-150 in-lb (14.6-16.9 N•m)																														
▲18	Inflate tires to 28-32 psi (1.93-2.21 bar/0.193-0.221 MPa)																														
▲24	Torque to 17-23 ft-lb (23.0-31.1 N•m)																														
▲31	Torque to 25-35 in-lb (2.8-3.9 N•m)																														
▲33	Torque to 70-90 in-lb (7.9-10.1 N•m)																														
▲44	Torque to 30-35 in-lb (3.3-3.9 N•m)																														
▲46	Torque to 70-80 ft-lb (94.9-108.4 N•m)																														
▲47	Torque to 200-230 in-lb (22.5-25.9 N•m)																														
▲49	Torque to 170-190 in-lb (19.2-21.4 N•m)																														
55†		ROTOR, clutch, 4 in.	1																												
56†	101682	SCREW, cap, sch	4																												
64	241920	DEFLECTOR, threaded	1																												
65▲	15F638	LABEL, warning fire and skin, GMAX	1																												
66†		ARMATURE, clutch, 4 in.	1																												
67	244240	HOSE, coupled, <i>includes 64</i>	1																												
72	15F250	WASHER, thrust	1																												
83	15F855	PIN, pump	1																												
85	15E807	TUBE, intake	1																												
86	287411	FRAME, standard, cart	1																												
92	118494	PACKING, o-ring	1																												
93	241008	ROD, connecting	1																												
95	196178	FITTING	1																												
96	156306	WASHER, flat	2																												
99★	16C457	HANGER, pail	1																												
100	119420	WHEEL, pneumatic	2																												
101	113161	SCREW, flange, hex hd	3																												
114	16X822	BOX, control	1																												
119	15E891	CLIP, retaining	2																												

# GMAX II 3900 Lo-Boy Series

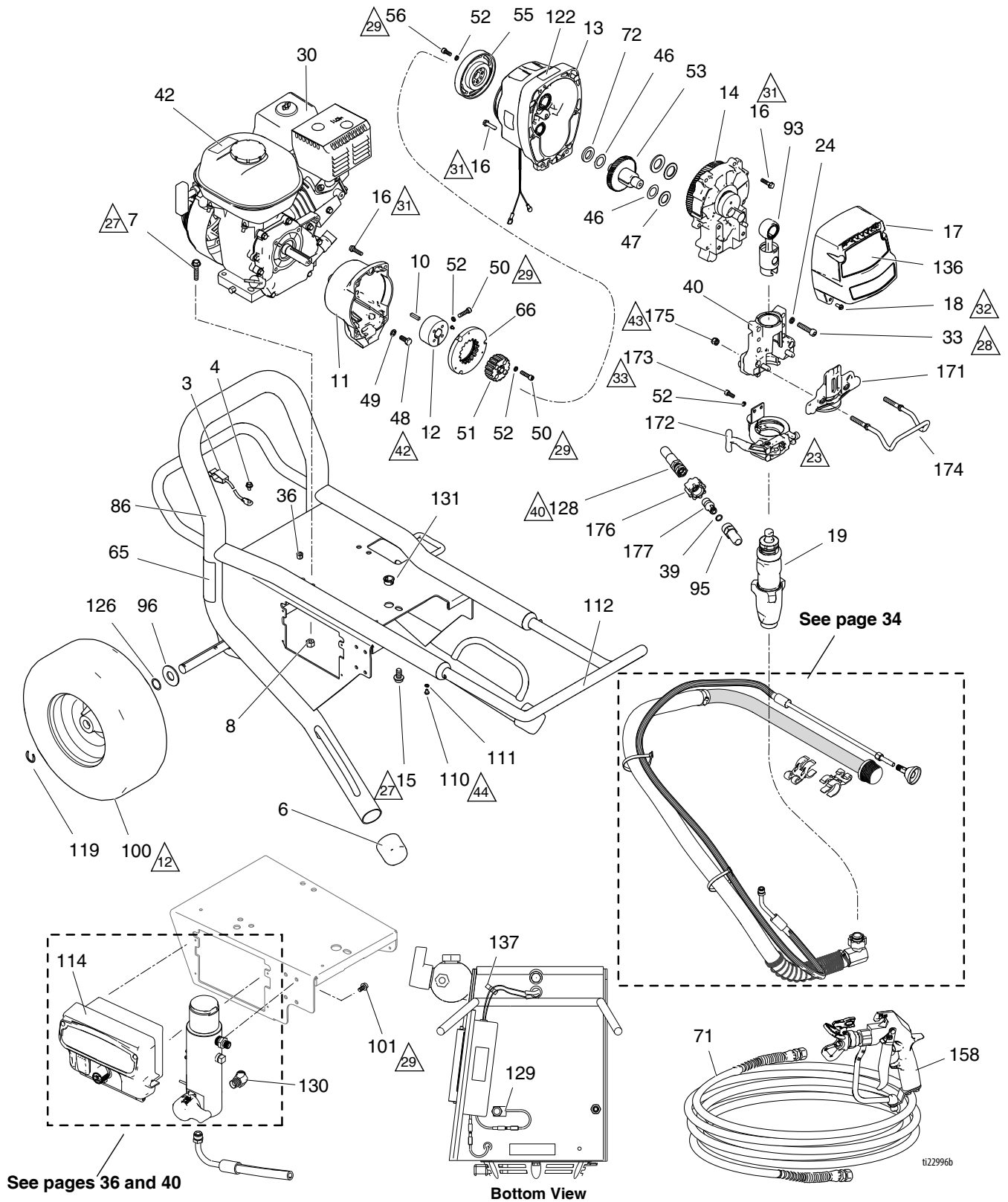

# Parts List - GMAX II 3900 Lo-Boy Series

Ref.	Part	Description	Qty.	Ref.	Part	Description	Qty.
3	237686	WIRE, ground assembly w/ clamp	1	126	116038	WASHER, wave spring	2
4	112798	SCREW, thread forming, hex hd	1	128	16X950	HOSE, coupled	1
6	276974	CAP, leg	2	129	119579	CONDUCTOR, ground	1
7	110837	SCREW, flange, hex	2	130	122533	FITTING, 45 deg	1
8	110838	NUT, lock	2	131	119569	BUSHING, strain relief	1
10	183401	KEY, parallel	1	136	17E928	LABEL, brand, GMAX 3900	1
11	15E535	HOUSING, clutch, machine	1	137	114687	CLIP, retainer	1
12	193680	COLLAR, shaft	1	158	17Y043	GUN, Contractor PC, RAC X	1
13	287463	HOUSING, pinion, 3900	1	171★	16X228	PLATE, front, 3900, PC II	1
14	287467	HOUSING, drive, 3900, <i>includes 14a, 14b</i>	1	172★	16X322	CLAMP, pump, small	1
14a	116191	WASHER, thrust	1	173★	101550	SCREW, cap, sch	2
14b	107089	WASHER, race, thrust	1	174★	16C457	HANGER, pail	1
15	112395	SCREW, cap, flng hd	1	175★	111040	NUT, lock, insert, nylock, 5/16	2
16	119426	SCREW, mach, hex washer hd	10	176	120583	NUT, hand	1
17	16Y747	COVER, front, 3900 (includes 18)	1	177	16X833	FITTING, quick disconnect, 3/8 npsm	1
18★	118444	SCREW, mach, slot hex wash hd	4		17H899	KIT, gauge, 1/4" (not shown)	1
19	16X414	PUMP, displacement 3900, <i>includes 85, 92, 95</i>	1	▲	16Y631	LABEL, warning	1
24★	104008	WASHER, lock, spring	4	▲	16Y632	LABEL, warning	1
30	108879	ENGINE, gasoline, 4.0 HP	1	▲	16Y633	LABEL, warning	1
33	17E917	SCREW, cap, socket head, SST	4	▲		CARD, Medical Alert	
36	114678	BUSHING, strain relief	1		222385	English, French, Spanish	
39	107505	PACKING, o-ring	1		17A134	English, Chinese, Spanish	
40★		HOUSING, bearing 3900	1		17R476	English, Spanish, Portuguese	
42▲	194126	LABEL, warning	1	▲ Replacement Danger and Warning Labels, Tags and Cards are available at no cost.			
46	114699	WASHER, thrust	2	† Included in Clutch Replacement Kit 241109			
47	114672	WASHER, thrust	1	★ Included in Bearing Housing Kit 24V087			
48	108842	SCREW, cap, hex hd	4	<b>Part Specifications:</b>			
49	100214	WASHER, lock	4				
50†	108803	SCREW, hex, socket head	6				
51†		HUB, armature	1				
52†★	105510	WASHER, lock, spring (hi-collar)	12				
53	287653	GEAR, combination 3900	1				
55†		ROTOR, clutch, 4 in.	1				
56†	101682	SCREW, cap, sch	4				
65▲	15F638	LABEL, GMAX warning fire and skin	1				
66†		ARMATURE, clutch, 4 in.	1				
71	240794	HOSE, coupled, 1/4 in. x 50 ft	1				
72	15F250	WASHER, thrust	1				
86	16Y519	FRAME	1				
93	24V084	ROD, connecting 3900	1				
95	16Y579	FITTING	1				
96	156306	WASHER, flat	2				
100	119509	WHEEL, pneumatic	2				
101	113161	SCREW, flange, hex hd	3				
110	109032	SCREW, mach, pnh	4				
111	100020	WASHER, lock, 3900 only	4				
112	16Y780	HANDLE, cart	1				
114	16X822	BOX, control	1				
119	15E891	CLIP, retaining	2				
122▲	290228	LABEL, caution	1				

Ref.	Instruction
▲2	Inflate tires to 28-32 psi (1.93-2.21 bar/0.193-0.221 MPa)
▲3	Torque clamp adjustment bolt to 90-110 in-lb (10.1-12.4 N•m) with reference 19 installed and ProConnect in locked position.
▲7	Torque to 17-23 ft-lb (23.0-31.1 N•m)
▲8	Torque to 190-210 in-lb (21.4-23.7 N•m)
▲9	Torque to 115-135 in-lb (12.9-15.2 N•m)
▲1	Torque to 130-150 in-lb (14.6-16.9 N•m)
▲2	Torque to 30-45 in-lb (3.3-5.0 N•m)
▲3	Torque to 90-110 in-lb (10.1-12.4 N•m)
▲0	Torque to 60-65 in-lb (6.7-7.3 N•m)
▲2	Torque to 170-190 in-lb (19.2-21.4 N•m)
▲3	Torque to 200-230 in-lb (22.5-25.9 N•m)
▲4	Torque to 25-35 in-lb (2.8-3.9 N•m)

# GMAX II 3900 ProContractor Series

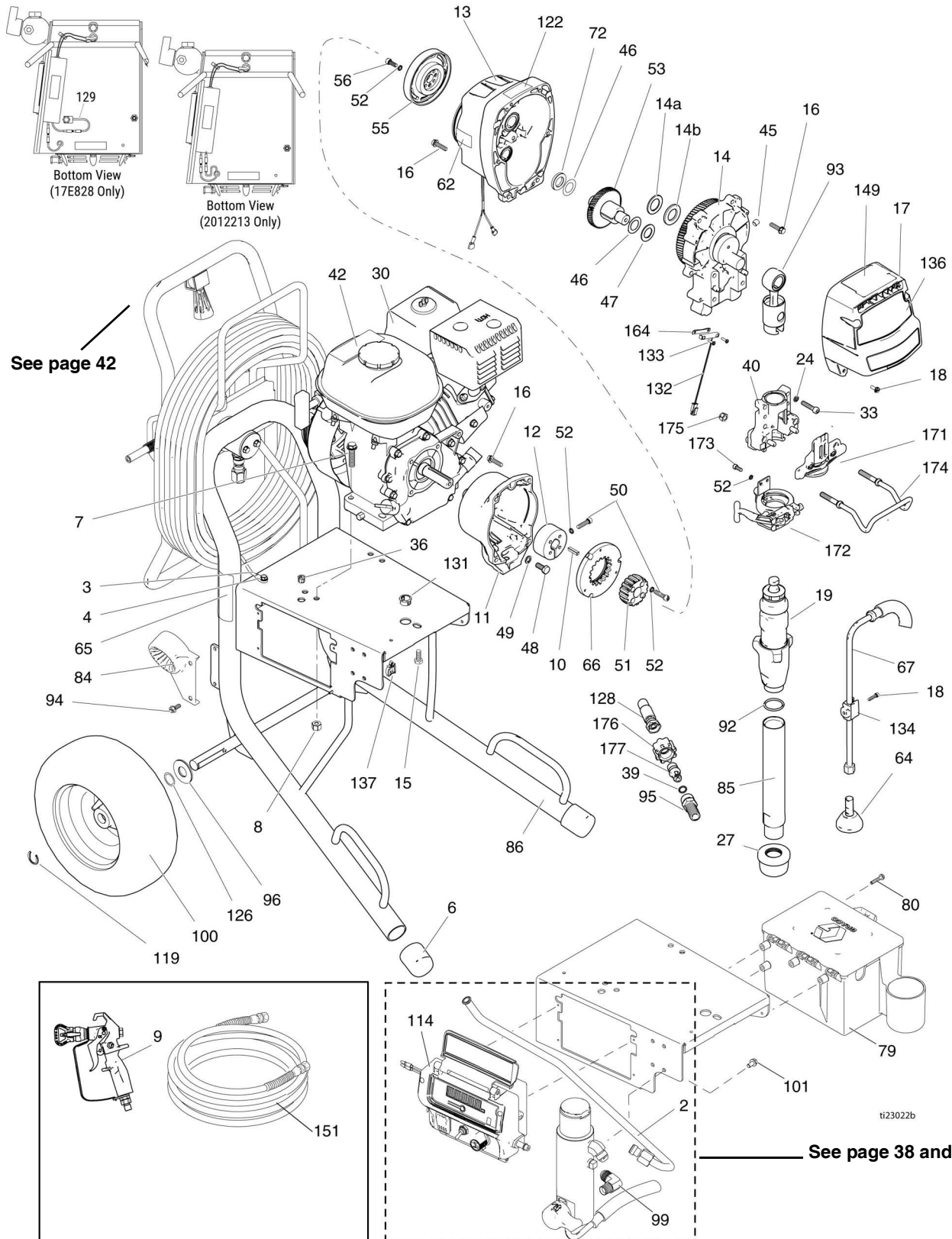

# Parts List - GMAX II 3900 ProContractor Series

Ref.	Part	Description	Qty.	Ref.	Part	Description	Qty.
2	16C384	TUBE, 3900	1	129	119579	CONDUCTOR, ground (17E828 only)	1
3	237686	WIRE, ground assembly w/ clamp	1	131	119569	BUSHING, strain relief	1
4	112798	SCREW, thread forming, hex hd	1	132	119562	SWITCH, reed w/connector	1
6	15C871	CAP, leg	2	133	114528	SCREW, mach, phillips, pnhd	2
7	110837	SCREW, flange, hex	2	134	16X203	CLIP, drain line	1
8	110838	NUT, lock	2	135	15F354	FUNNEL, oil (not shown)	1
9	17Y043	GUN, contractor, RAC X, packaged	1	136	17E928	LABEL, brand, GMAX 3900	1
10	183401	KEY, parallel	1	137	114687	CLIP, retainer	1
11	15E535	HOUSING, clutch, machine	1	149	17E934	LABEL, series, GMAX, Pro	1
12	193680	COLLAR, shaft	1	151	240794	HOSE, coupled, 1/4 in x 50 ft	1
13	287463	HOUSING, pinion, 3900	1	164	15F947	SHIELD, magnetic	1
14	287467	HOUSING, drive, 3900, <i>includes 14a, 14b</i>	1	171★	16X228	PLATE, front, 3900, PC II	1
14a	116191	WASHER, thrust	1	172★	16X322	CLAMP, pump, small	1
14b	107089	WASHER, race, thrust	1	173★	101550	SCREW, cap, sch	2
15	112395	SCREW, cap, flng hd	1	174★	16C457	HANGER, pail	1
16	119426	SCREW, mach, hex washer hd	10	175★	111040	NUT, lock, insert, nylock, 5/16	2
17	16Y747	COVER, front, 3900, <i>includes 18</i>	1	176	120583	NUT, hand	1
18★	118444	SCREW, mach, slot hex wash hd	5	177	16X833	FITTING, quick disconnect, 3/8 npsm	1
19	17H823	PUMP, displacement 3900, <i>includes 85, 92, 95</i>	1	▲	16Y631	LABEL, warning	1
24★	104008	WASHER, lock, spring	4	▲	16Y632	LABEL, warning	1
27	15V573	STRAINER, 1-11 1/2 NPSM, crushproof	1	▲	16Y633	LABEL, warning	1
30	108879	ENGINE, gasoline, 4.0 HP (17E828)	1	▲		CARD, Medical Alert	1
	114530	ENGINE, gasoline, 5.5 HP (2012213)	1		222385	English, French, Spanish	
33	17E917	SCREW, cap, socket head, SST	4		17A134	English, Chinese, Spanish	
36	114678	BUSHING, strain relief	1		17R476	English, Spanish, Portuguese	
39	107505	PACKING, o-ring	1				
40★		HOUSING, bearing 3900	1				
42▲	194126	LABEL, warning	1				
45	116618	MAGNET	1				
46	114699	WASHER, thrust	2				
47	114672	WASHER, thrust	1				
48	108842	SCREW, cap, hex hd	4				
49	100214	WASHER, lock	4				
50†	108803	SCREW, hex, socket head	6				
51†		HUB, armature	1				
52†★	105510	WASHER, lock, spring (hi-collar)	12				
53	287653	GEAR, combination 3900	1				
55†		ROTOR, clutch, 4 in.	1				
56†	101682	SCREW, cap, sch	4				
62		LABEL, USA made with Honda	1				
64	241920	DEFLECTOR, threaded	1				
65▲	15F638	LABEL, GMAX warning fire and skin	1				
66†		ARMATURE, clutch, 4 in.	1				
67	244240	HOSE, coupled, <i>includes 64</i>	1				
72	15F250	WASHER, thrust	1				
79	287253	TOOL BOX, <i>includes 94</i>	1				
80	118852	SCREW, thd forming, hex washer hd	3				
85	15E807	TUBE, intake	1				
84	278083	GUIDE, hose,	1				
86	24D045	FRAME, hose reel	1				
92	118494	PACKING, o-ring	1				
93	24V084	ROD, connecting 3900	1				
94	117633	SCREW, slot hex wash hd	2				
95	16Y579	FITTING	1				
96	156306	WASHER, flat	2				
99	125926	FITTING, 90 deg	1				
100	119420	WHEEL, pneumatic	2				
101	113161	SCREW, flange, hex hd	3				
114	16X821	BOX, control	1				
119	15E891	CLIP, retaining	2				
122▲	290228	LABEL, caution	1				
126	116038	WASHER, wave spring	2				
128	16X904	HOSE, coupled	1				

▲ Replacement Danger and Warning Labels, Tags and Cards are available at no cost.

† Included in Clutch Replacement Kit 241109

★ Included in Bearing Housing Kit 24V087

## Part Specifications:

Ref.	Instruction
▲2	Inflate tires to 28-32 psi (1.93-2.21 bar/0.193-0.221 MPa)
▲3	Torque clamp adjustment bolt to 90-110 in-lb (10.1-12.4 N•m) with reference 19 installed and ProConnect in locked position.
▲4	Torque to 38-42 ft-lb (51.5-56.9 N•m)
▲5	Torque to 120-130 in-lb (13.5-14.6 N•m)
▲6	Torque to 40-45 in-lb (4.5-5.0 N•m)
▲7	Torque to 17-23 ft-lb (23.0-31.1 N•m)
▲8	Torque to 190-210 in-lb (21.4-23.7 N•m)
▲9	Torque to 115-135 in-lb (12.9-15.2 N•m)
▲0	Torque to 30-40 in-lb (3.3-4.5 N•m)
▲1	Torque to 130-150 in-lb (14.6-16.9 N•m)
▲2	Torque to 30-45 in-lb (3.3-5.0 N•m)
▲3	Torque to 90-110 in-lb (10.2-12.4 N•m)
▲5	Torque to 8-12 in-lb (0.9-1.35 N•m)
▲7	Torque to 70-90 in-lb (7.9-10.1 N•m)
▲2	Torque to 170-190 in-lb (19.2-21.4 N•m)
▲3	Torque to 200-230 in-lb (22.5-25.9 N•m)

# GMAX II 5900 and 5900 HD Standard Series

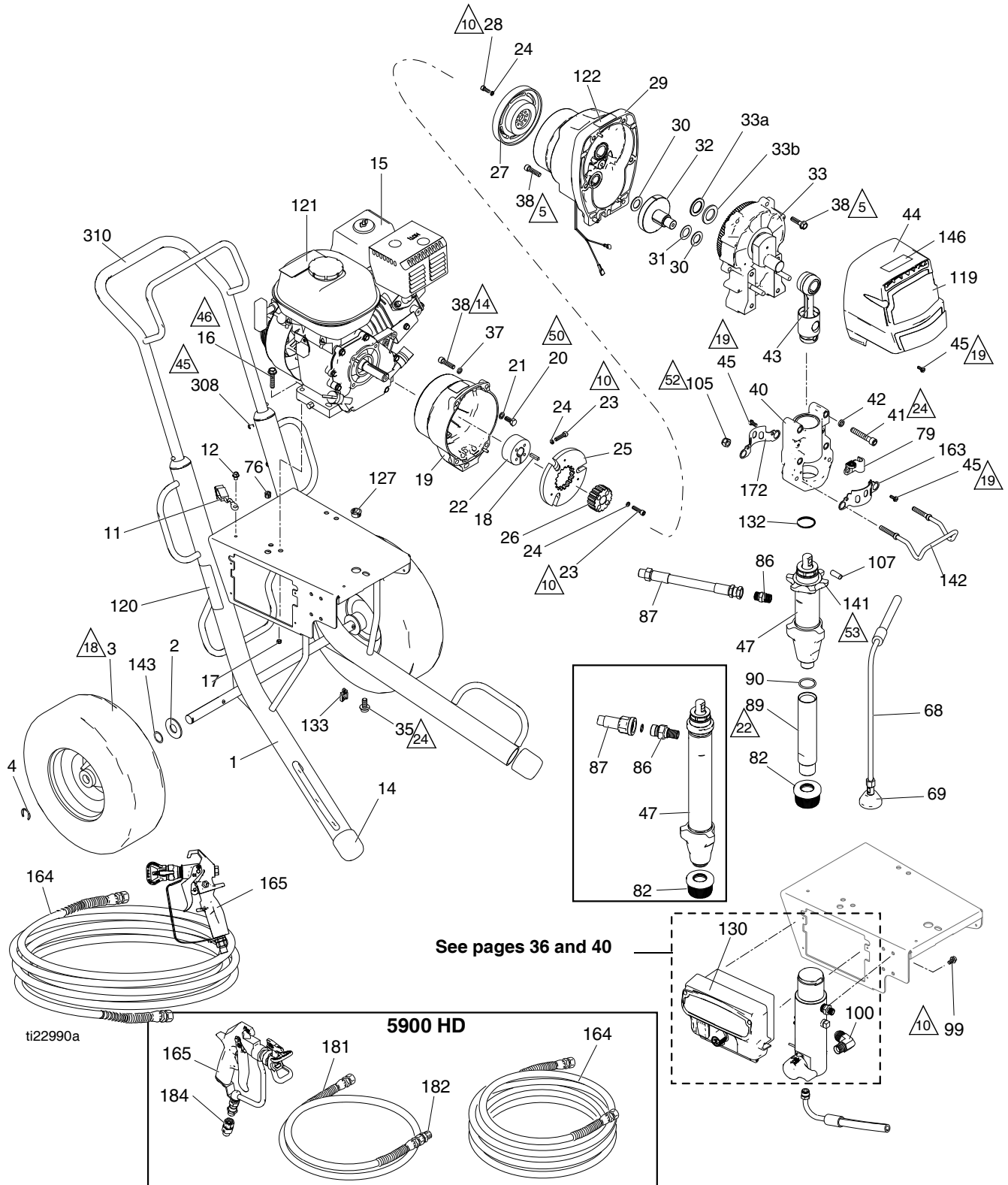

# Parts List - GMAX II 5900 and 5900 HD Standard Series

Ref.	Part	Description	Qty.	Ref.	Part	Description	Qty.
1	287370	FRAME, standard, cart	1	121▲	194126	LABEL, warning	1
2	156306	WASHER, flat	2	122▲	290228	LABEL, caution	1
3	119509	WHEEL, pneumatic	2	127	119569	BUSHING, strain relief	1
4	15E891	CLIP, retaining	2	130	16X822	BOX, control	1
11	237686	WIRE, ground assembly w/ clamp	1	132	119778	SPRING, retaining	1
12	112798	SCREW, thread forming, hex hd	1	133	114687	CLIP, retainer	1
14	276974	CAP, leg	2	141	193031	NUT, retaining	1
15	116080	ENGINE, gas, 6.5 HP, Honda	1	142★	16C457	HANGER, pail	1
16	110837	SCREW, flange, hex	2	143	116038	WASHER, wave spring	2
17	110838	NUT, lock	2	146	17E933	LABEL, series, std	1
18	183401	KEY, parallel	1	155	15F354	FUNNEL, oil (not shown)	1
19	15E277	HOUSING, clutch, mach 5900/7900	1	160	102982	PACKING, o-ring, 5900 HD	1
20	108842	SCREW, cap, hex hd	4	163★	16X770	SHIELD, pump rod	1
21	100214	WASHER, lock	4	164	240794	HOSE, coupled, 1/4 in. x 50 ft, 5900	1
22	193680	COLLAR, shaft	1		240797	HOSE, coupled, 3/8 in. x 50ft, 5900 HD	1
23†	108803	SCREW, hex, socket head	6	165	17Y043	GUN, Contractor PC, RAC X, 5900	1
24†	105510	WASHER, lock, spring (hi-collar)	10		241705	GUN, spray, texture, 5900 HD	1
25†		ARMATURE, clutch, 5 in.	1	172	15C762	SHIELD, pump rod	1
26†		HUB, armature	1	181	241735	HOSE, cpld, 1/4 in. x 3 ft, 5900 HD	1
27†		ROTOR, clutch, 5 in.	1	182	159841	BUSHING, 7250 psi, 3/8 in. x 1/4 in., 5900 HD	1
28†	101682	SCREW, cap, sch	4				
29	287465	HOUSING, pinion, 5900	1	184	189018	SWIVEL, assembly, 5900 HD	1
30	114672	WASHER, thrust	2	308	108795	SCREW, mach, pnh	4
31	114699	WASHER, thrust	1	310	24A250	HANDLE, cart (standard only)	1
32	287460	GEAR, combination, 5900	1		17H899	KIT, gauge, 1/4" (not shown)	1
33	287469	HOUSING, drive, 5900, <i>includes 33a, 33b</i>	1		17H900	KIT, gauge, 3/8" (not shown)	1
33a	116192	WASHER, thrust	1	▲	16Y631	LABEL, warning	1
33b	194173	WASHER	1	▲	16Y632	LABEL, warning	1
35	112395	SCREW, cap, flng hd	1	▲	16Y633	LABEL, warning	1
37	104008	WASHER, lock, spring	4	▲		CARD, Medical Alert	
38	15C753	SCREW, mach, hex wash hd	6		222385	English, French, Spanish	
40★		HOUSING, bearing, 5900	1		17A134	English, Chinese, Spanish	
41★	17E789	SCREW, cap, socket head, SST	4		17R476	English, Spanish, Portuguese	
42★	106115	WASHER, lock (hi-collar)	4				
43	24V021	ROD, connecting, 5900	1				
44	16Y748	COVER, front, 5900, <i>includes 45</i>	1				
45	118444	SCREW, mach, slot hex wash hd	8				
47		PUMP, displacement					
	16Y706	5900, <i>includes 86, 89, 90</i>	1				
	17H829	5900 HD, <i>includes 86</i>	1				
68	244240	HOSE, coupled, <i>includes 69</i>	1				
69	241920	DEFLECTOR, threaded	1				
76	114678	BUSHING, strain relief	1				
79★	278204	CLIP, drain line	1				
82	189920	STRAINER, (1-11 1/2 NPSM)	1				
86		FITTING	1				
	196178	5900					
	16X834	5900 HD					
87		HOSE, coupled	1				
	16X909	5900					
	16X905	5900 HD					
89	248215	TUBE, intake	1				
90	118494	PACKING, o-ring	1				
99	113161	SCREW, flange, hex hd	3				
100	125926	FITTING, 90 deg (5900 HD)	1				
105★	111040	NUT, lock, insert, nylock, 5/16	2				
107	15F856	PIN, pump, 5900	1				
119		LABEL, front, GMAX II 5900					
	17E929	5900	1				
	17E936	5900 HD	1				
120▲	15F638	LABEL, GMAX warning fire & skin	1				

▲ Replacement Danger and Warning Labels, Tags and Cards are available at no cost.

† Included in Clutch Replacement Kit 241113

★ Included in Bearing Housing Kit 24V027

## Part Specifications:

Ref.	Instruction
▲5	Torque to 190-210 in-lb (21.5-23.7 N•m)
▲10	Torque to 115-135 in-lb (12.9-15.3 N•m)
▲14	Torque to 130-150 in-lb (14.7-16.9 N•m)
▲18	Inflate tires to 28-32 psi (1.93-2.21 bar/0.193-0.221 MPa)
▲19	Torque to 30-35 in-lb (3.4-3.9 N•m)
▲22	Torque to 70-90 in-lb (7.9-10.2 N•m)
▲24	Torque to 23-29 ft-lb (31.2-39.3 N•m)
▲45	Torque to 25-35 in-lb (2.8-3.9 N•m)
▲46	Torque to 17-23 ft-lb (23.1-31.2 N•m)
▲50	Torque to 170-190 in-lb (19.2-21.5 N•m)
▲52	Torque to 200-230 in-lb (22.6-25.9 N•m)
▲53	Torque to 75 +/- 5 ft-lb (101.7 +/- 6.8 N•m)

# GMAX II 5900 Lo-Boy Series

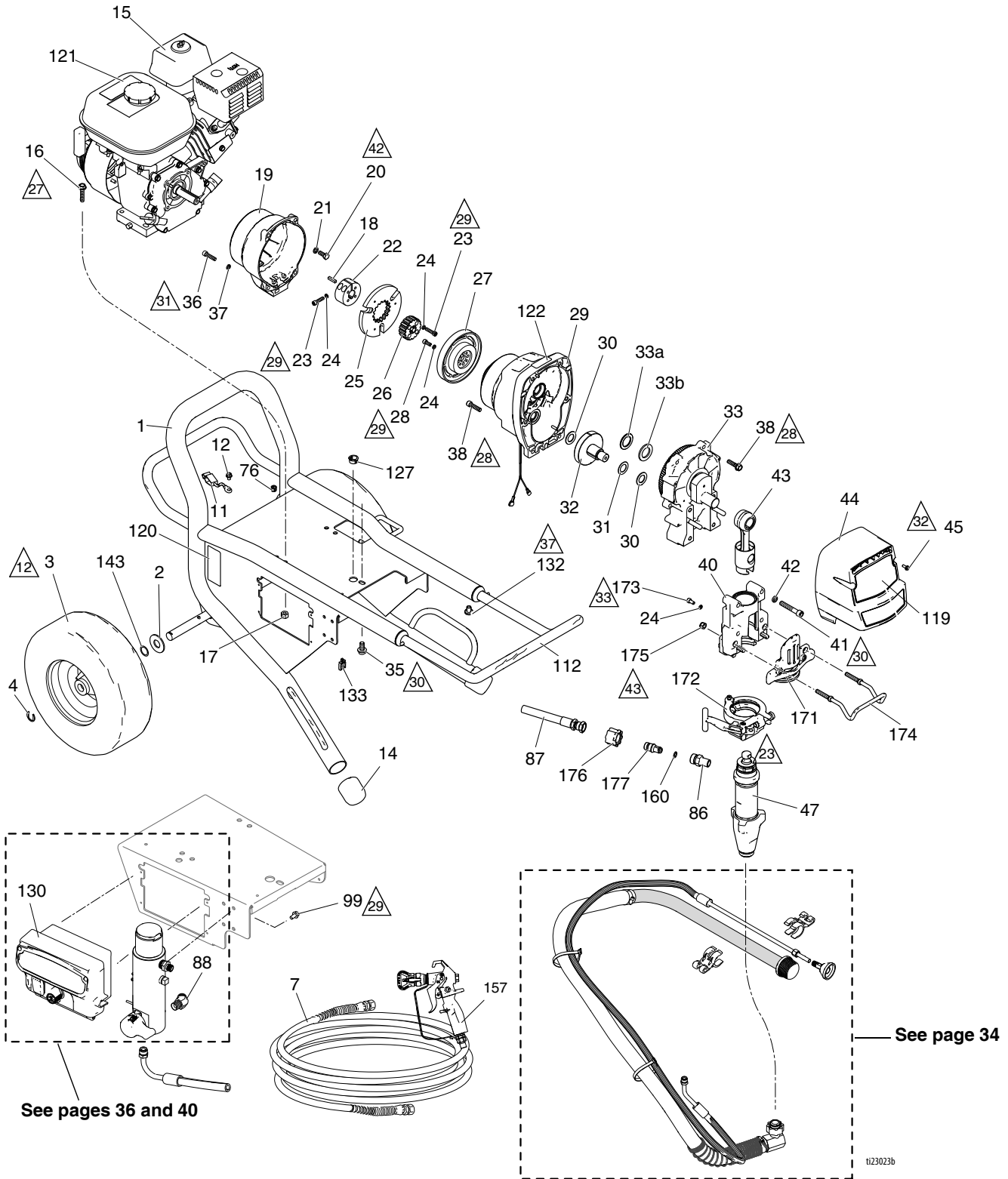

# Parts List - GMAX II 5900 Lo-Boy Series

Ref.	Part	Description	Qty.	Ref.	Part	Description	Qty.																										
1	16Y519	FRAME, cart	1	130	16X822	BOX, control	1																										
2	156306	WASHER, flat	2	132	109032	SCREW, mach, pnh	4																										
3	119509	WHEEL, pneumatic	2	133	114687	CLIP, retainer	1																										
4	15E891	CLIP, retaining	2	143	116038	WASHER, wave spring	2																										
7	240794	HOSE, coupled, 1/4 in. x 50 ft	1	157	17Y043	GUN, Contractor PC, RAC X	1																										
11	237686	WIRE, ground assembly w/ clamp	1	160	107505	PACKING, o-ring	1																										
12	112798	SCREW, thread forming, hex hd	1	171★	16X385	PLATE, front, ProConnect II, 5900 Lo-Boy	1																										
14	276974	CAP, leg	2	172★	16X324	CLAMP, pump, large, 5900 Lo-Boy	1																										
15	116080	ENGINE, gas, 6.5 HP, Honda	1	173★	101550	SCREW, cap, sch, 5900 Lo-Boy	2																										
16	110837	SCREW, flange, hex	2	174★	16C457	HANGER, pail, 5900 Lo-Boy	1																										
17	110838	NUT, lock	2	175★	111040	NUT, lock, insert, nylock, 5/16 5900 Lo-Boy	2																										
18	183401	KEY, parallel	1	176	120583	NUT, hand, 5900 Lo-Boy	1																										
19	15E277	HOUSING, clutch, mach 5900/7900	1	177	16X833	FITTING, quick disconnect, 3/8 npsm, 5900 Lo-Boy	1																										
20	108842	SCREW, cap, hex hd	4		17H899	KIT, gauge, 1/4" (not shown)	1																										
21	100214	WASHER, lock	4	▲	16Y631	LABEL, warning	1																										
22	193680	COLLAR, shaft	1	▲	16Y632	LABEL, warning	1																										
23†	108803	SCREW, hex, socket head	6	▲	16Y633	LABEL, warning	1																										
24†	105510	WASHER, lock, spring (hi-collar)	12	▲		CARD, Medical Alert																											
25†		ARMATURE, clutch, 5 in.	1		222385	English, French, Spanish																											
26†		HUB, armature	1		17A134	English, Chinese, Spanish																											
27†		ROTOR, clutch, 5 in.	1		17R476	English, Spanish, Portuguese																											
28†	101682	SCREW, cap, sch	4	▲ Replacement Danger and Warning Labels, Tags and Cards are available at no cost.																													
29	287465	HOUSING, pinion, 5900	1	† Included in Clutch Replacement Kit 241113																													
30	114672	WASHER, thrust	2	★ Included in Bearing Housing Kit 24V088																													
31	114699	WASHER, thrust	1	<b>Part Specifications:</b>																													
32	287460	GEAR, combination, 5900	1	<table border="1"><thead><tr><th>Ref.</th><th>Instruction</th></tr></thead><tbody><tr><td>▲22</td><td>Inflate tires to 28-32 psi (1.93-2.21 bar/0.193-0.221 MPa)</td></tr><tr><td>▲23</td><td>Torque clamp adjustment bolt to 140-160 in-lb (15.8-18.1 N•m) with reference 47 installed and ProConnect in locked position.</td></tr><tr><td>▲27</td><td>Torque to 17-23 ft-lb (23.1-31.2 N•m)</td></tr><tr><td>▲28</td><td>Torque to 190-210 in-lb (21.5-23.7 N•m)</td></tr><tr><td>▲29</td><td>Torque to 115-135 in-lb (12.9-15.3 N•m)</td></tr><tr><td>▲30</td><td>Torque to 23-29 ft-lb (31.2-39.3 N•m)</td></tr><tr><td>▲31</td><td>Torque to 130-150 in-lb (14.7-16.9 N•m)</td></tr><tr><td>▲32</td><td>Torque to 30-45 in-lb (3.9-5.1 N•m)</td></tr><tr><td>▲33</td><td>Torque to 90-110 in-lb (10.2-12.4 N•m)</td></tr><tr><td>▲37</td><td>Torque to 25-35 in-lb (2.8-3.9 N•m)</td></tr><tr><td>▲42</td><td>Torque to 170-190 in-lb (19.2-21.5 N•m)</td></tr><tr><td>▲43</td><td>Torque to 200-230 in-lb (22.6-25.9 N•m)</td></tr></tbody></table>				Ref.	Instruction	▲22	Inflate tires to 28-32 psi (1.93-2.21 bar/0.193-0.221 MPa)	▲23	Torque clamp adjustment bolt to 140-160 in-lb (15.8-18.1 N•m) with reference 47 installed and ProConnect in locked position.	▲27	Torque to 17-23 ft-lb (23.1-31.2 N•m)	▲28	Torque to 190-210 in-lb (21.5-23.7 N•m)	▲29	Torque to 115-135 in-lb (12.9-15.3 N•m)	▲30	Torque to 23-29 ft-lb (31.2-39.3 N•m)	▲31	Torque to 130-150 in-lb (14.7-16.9 N•m)	▲32	Torque to 30-45 in-lb (3.9-5.1 N•m)	▲33	Torque to 90-110 in-lb (10.2-12.4 N•m)	▲37	Torque to 25-35 in-lb (2.8-3.9 N•m)	▲42	Torque to 170-190 in-lb (19.2-21.5 N•m)	▲43	Torque to 200-230 in-lb (22.6-25.9 N•m)
Ref.	Instruction																																
▲22	Inflate tires to 28-32 psi (1.93-2.21 bar/0.193-0.221 MPa)																																
▲23	Torque clamp adjustment bolt to 140-160 in-lb (15.8-18.1 N•m) with reference 47 installed and ProConnect in locked position.																																
▲27	Torque to 17-23 ft-lb (23.1-31.2 N•m)																																
▲28	Torque to 190-210 in-lb (21.5-23.7 N•m)																																
▲29	Torque to 115-135 in-lb (12.9-15.3 N•m)																																
▲30	Torque to 23-29 ft-lb (31.2-39.3 N•m)																																
▲31	Torque to 130-150 in-lb (14.7-16.9 N•m)																																
▲32	Torque to 30-45 in-lb (3.9-5.1 N•m)																																
▲33	Torque to 90-110 in-lb (10.2-12.4 N•m)																																
▲37	Torque to 25-35 in-lb (2.8-3.9 N•m)																																
▲42	Torque to 170-190 in-lb (19.2-21.5 N•m)																																
▲43	Torque to 200-230 in-lb (22.6-25.9 N•m)																																
33	287469	HOUSING, drive, 5900, includes 33a, 33b	1																														
33a	116192	WASHER, thrust	1																														
33b	194173	WASHER	1																														
35	112395	SCREW, cap, flng hd	1																														
36	102962	SCREW, cap sch	4																														
37	104008	WASHER, lock, spring	4																														
38	15C753	SCREW, mach, hex wash hd	6																														
40★		HOUSING, bearing, 5900	1																														
41★	17E789	SCREW, cap, socket head, SST	4																														
42★	106115	WASHER, lock (hi-collar)	4																														
43	24V085	ROD, connecting, 5900	1																														
44	16Y748	COVER, front, 5900, includes 45	1																														
45★	118444	SCREW, mach, slot hex wash hd	4																														
47	16X419	PUMP, displacement, 5900, includes 86	1																														
76	114678	BUSHING, strain relief	1																														
86	15J413	FITTING	1																														
87	16X950	HOSE, coupled	1																														
88	122533	FITTING, 45 deg	1																														
99	113161	SCREW, flange, hex hd	3																														
112	16Y780	HANDLE, cart	1																														
119	17E929	LABEL, brand, GMAX 5900	1																														
120▲	15F638	LABEL, GMAX warning fire & skin	1																														
121▲	194126	LABEL, warning	1																														
122▲	290228	LABEL, caution	1																														
127	119569	BUSHING, strain relief	1																														

# GMAX II 5900 and 5900 HD ProContractor Series

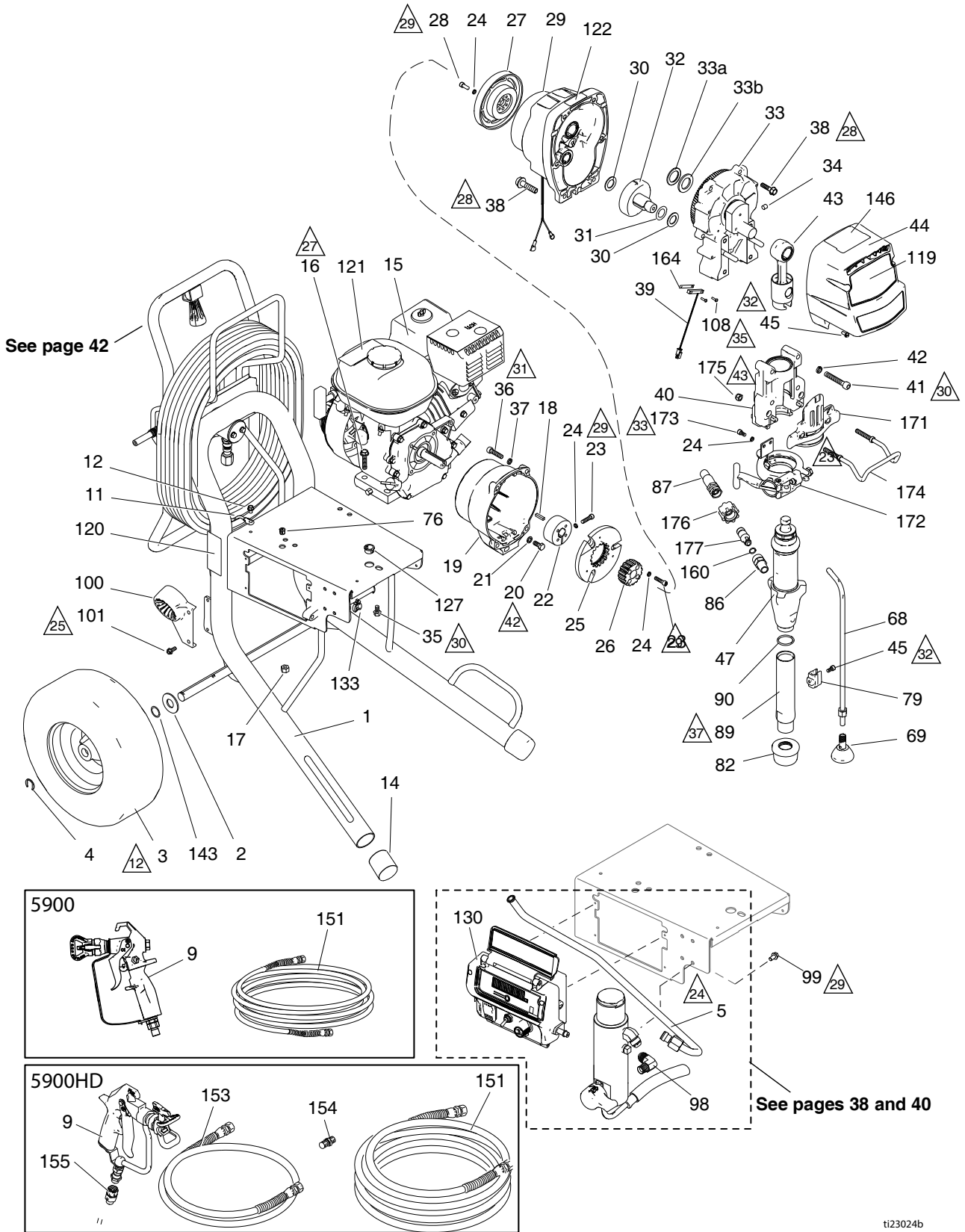

ti23024b

# Parts List - GMAX II 5900 and 5900 HD ProContractor Series

Ref.	Part	Description	Qty.	Ref.	Part	Description	Qty.
1	24D047	FRAME, hose reel, cart	1	120▲	15F638	LABEL, GMAX warning fire & skin	1
2	156306	WASHER, flat	2	121▲	194126	LABEL, warning	1
3	119509	WHEEL, pneumatic	2	122▲	290228	LABEL, caution	1
4	15E891	CLIP, retaining	2	127	119569	BUSHING, strain relief	1
5	16C381	TUBE, GMAX 5900/7900	1	130	16X821	BOX, control	1
9	17Y043	GUN, Contractor PC, RAC X, 5900	1	133	114687	CLIP, retainer	1
	241705	GUN, spray, texture, 5900 HD	1	134	15F354	FUNNEL, oil (not shown)	1
11	237686	WIRE, ground assembly w/ clamp	1	143	116038	WASHER, wave spring	2
12	112798	SCREW, thread forming, hex hd	1	146	17E934	LABEL, series, Pro	1
14	276974	CAP, leg	2	151	240794	HOSE, coupled, 1/4 in. x 50 ft, 5900	1
15	116080	ENGINE, gas, 6.5 HP, Honda	1		240797	HOSE, coupled, 3/8 in. x 50 ft, 5900 HD	1
16	110837	SCREW, flange, hex	2	153	241735	HOSE, cpld, 1/4 in. x 3 ft, 5900 HD	1
17	110838	NUT, lock	2	154	159841	BUSHING, 7250 psi, 3/8 x 1/4 in. 5900 HD	1
18	183401	KEY, parallel	1	155	189018	SWIVEL, assembly, 5900 HD	1
19	15E277	HOUSING, clutch, mach, 5900/7900	1	160		PACKING, o-ring	1
20	108842	SCREW, cap, hex hd	4		107505	5900	
21	100214	WASHER, lock	4		102982	5900 HD	
22	193680	COLLAR, shaft	1	164	15F947	SHIELD, magnetic	1
23†	108803	SCREW, hex, socket head	6	171★	16X385	PLATE, front, 5900, PC II	1
24†★	105510	WASHER, lock, spring (hi-collar)	12	172★	16X324	CLAMP, pump, large	1
25†		ARMATURE, clutch, 5 in.	1	173★	101550	SCREW, cap, sch	2
26†		HUB, armature	1	174★	16C457	HANGER, pail	1
27†		ROTOR, clutch, 5 in.	1	175★	111040	NUT, lock, insert, nylock, 5/16	2
28†	101682	SCREW, cap, sch	4	176	120583	NUT, hand	1
29	287465	HOUSING, pinion, 5900	1	177	16X833	FITTING, quick disconnect, 3/8 npsm	1
30	114672	WASHER, thrust	2	▲	16Y631	LABEL, warning	1
31	114699	WASHER, thrust	1	▲	16Y632	LABEL, warning	1
32	287460	GEAR, combination, 5900	1	▲	16Y633	LABEL, warning	1
33	287469	HOUSING, drive, 5900, <i>includes 33a, 33b</i>	1	▲		CARD, Medical Alert	
33a	116192	WASHER, thrust	1		222385	English, French, Spanish	
33b	194173	WASHER	1		17A134	English, Chinese, Spanish	
34	116618	MAGNET	1		17R476	English, Spanish, Portuguese	
35	112395	SCREW, cap, flng hd	1				
36	102962	SCREW, cap sch	4				
37	104008	WASHER, lock, spring	4				
38	15C753	SCREW, mach, hex wash hd	6				
39	119562	SWITCH, reed w/connector	1				
40★		HOUSING, bearing, 5900	1				
41★	17E789	SCREW, cap, socket head, SST	4				
42★	106115	WASHER, lock (hi-collar)	4				
43	24V085	ROD, connecting, 5900	1				
44	16Y748	COVER, front, 5900, <i>includes 45</i>	1				
45★	118444	SCREW, mach, slot hex wash hd	5				
47		PUMP, displacement					
	17H824	5900 ( <i>includes 86, 89, 90</i> )	1				
	17H833	5900 HD, <i>includes 86</i>	1				
68	244240	HOSE, coupled, <i>includes 69</i>	1				
69	241920	DEFLECTOR, threaded	1				
76	114678	BUSHING, strain relief	1				
79★	16X203	CLIP, drain line	1				
82	15V573	STRAINER, 1-11 1/2 NPSM, crushproof	1				
86		FITTING, pump, QD	1				
	16Y579	5900					
	16X834	5900 HD					
87		HOSE, coupled	1				
	16X904	3/8 in., 5900					
	16X905	1/2 in., 5900 HD					
89	248215	TUBE, intake	1				
90	118494	PACKING, o-ring	1				
98	125926	FITTING, 90 deg	1				
99	113161	SCREW, flange, hex hd	3				
100	278083	GUIDE, hose	1				
101	117633	SCREW, slot hex wash hd	2				
108	114528	SCREW, mach, phillips, pnhd	2				
119		LABEL, front, GMAX II, 5900					
	17E929	5900	1				
	17E936	5900 HD	1				

▲ Replacement Danger and Warning Labels, Tags and Cards are available at no cost.

† Included in Clutch Replacement Kit 241113

★ Included in Bearing Housing Kit 24V088

## Part Specifications:

Ref.	Instruction
▲2	Inflate tires to 28-32 psi (1.93-2.21 bar/0.193-0.221 MPa)
▲23	Torque clamp adjustment bolt to 140-160 in-lb (15.8-18.1 N•m) with reference 47 installed and ProConnect in locked position.
▲24	Torque to 38-42 ft-lb (51.5-56.9 N•m)
▲25	Torque to 120-130 in-lb (13.6-14.7 N•m)
▲26	Torque to 40-45 in-lb (4.5-5.1 N•m)
▲27	Torque to 17-23 ft-lb (23.1-31.2 N•m)
▲28	Torque to 190-210 in-lb (21.5-23.7 N•m)
▲29	Torque to 115-135 in-lb (12.9-15.3 N•m)
▲30	Torque to 23-29 ft-lb (31.2-39.3 N•m)
▲31	Torque to 130-150 in-lb (14.7-15.9 N•m)
▲32	Torque to 30-45 in-lb (3.4-5.1 N•m)
▲33	Torque to 90-110 in-lb (10.2-12.4 N•m)
▲35	Torque to 8-12 in-lb (0.9-1.4 N•m)
▲37	Torque to 70-90 in-lb (7.9-10.2 N•m)
▲42	Torque to 170-190 in-lb (19.2-21.2 N•m)
▲43	Torque to 200-230 in-lb (22.6-25.9 N•m)

# GMAX II 5900 IronMan Series

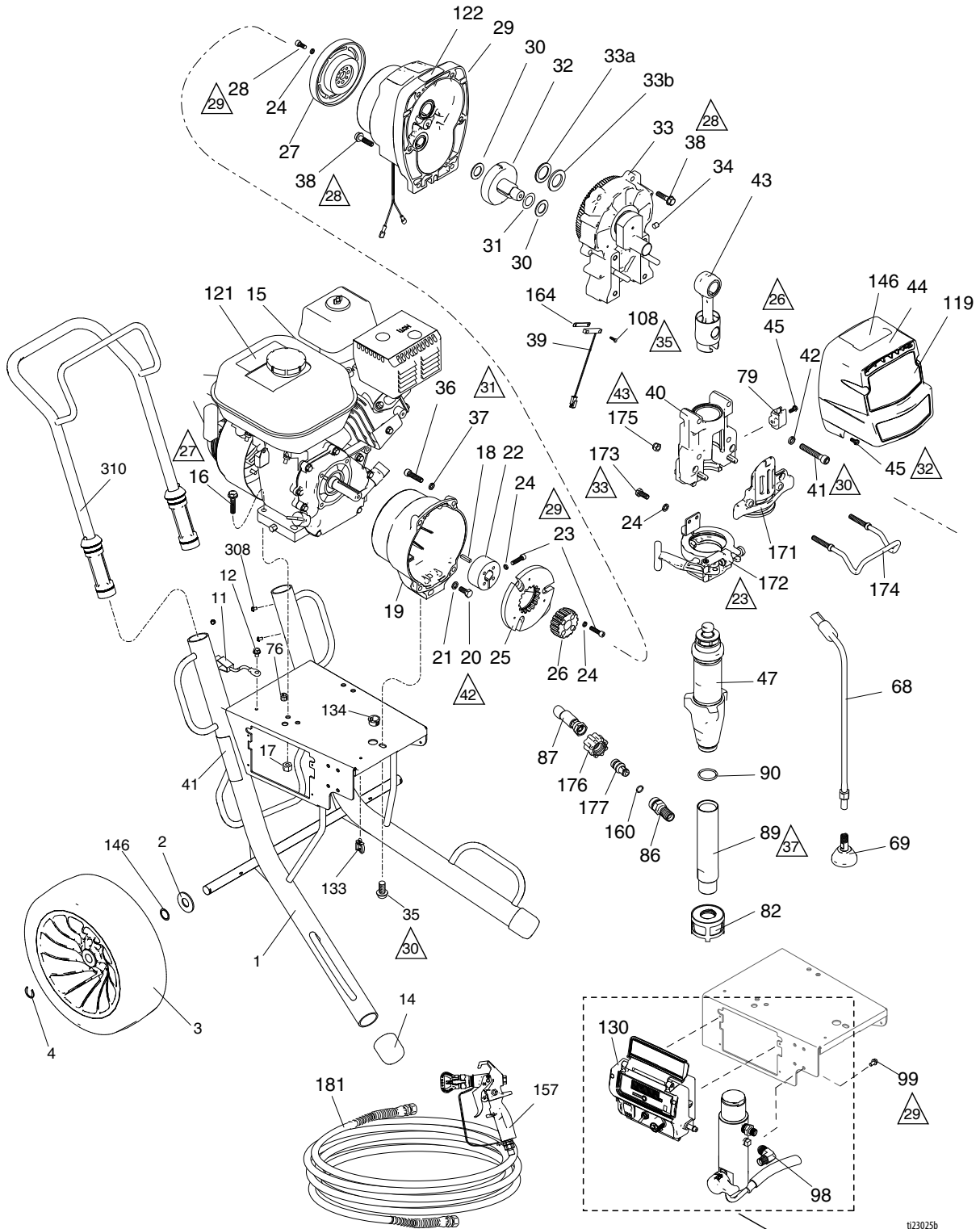

t23025b

See pages 38 and 40

# Parts List - GMAX II 5900 IronMan Series

Ref.	Part	Description	Qty.	Ref.	Part	Description	Qty.
1	287370	FRAME, cart	1	127	119569	BUSHING, strain relief	1
2	156306	WASHER, flat	2	130	16X821	BOX, control	1
3	17E687	WHEEL, flat proof, black, 13 in	2	133	114687	CLIP, retainer	1
4	120211	CLIP, retaining	2	134	15F354	FUNNEL, oil (not shown)	1
11	237686	WIRE, ground assembly w/ clamp	1	143	116038	WASHER, wave spring	2
12	112798	SCREW, thread forming, hex hd	1	146	17E935	LABEL, series, GMAX, Ironman	1
14	276974	CAP, leg	2	157	17Y043	GUN, Contractor PC, RAC X	1
15	116080	ENGINE, gas, 6.5 HP, Honda	1	160	107505	PACKING, o-ring	1
16	110837	SCREW, flange, hex	2	164	15F947	SHIELD, magnetic	1
17	110838	NUT, lock	2	171★	16X385	PLATE, front, 5900, PC II	1
18	183401	KEY, parallel	1	172★	16X324	CLAMP, pump, large	1
19	15E277	HOUSING, clutch, mach, 5900/7900	1	173★	101550	SCREW, cap, sch	2
20	108842	SCREW, cap, hex hd	4	174★	16C457	HANGER, pail	1
21	100214	WASHER, lock	4	175★	111040	NUT, lock, insert, nylock, 5/16	2
22	193680	COLLAR, shaft	1	176	120583	NUT, hand	1
23†	108803	SCREW, hex, socket head	6	177	16X833	FITTING, quick, disconnect, 3/8 npsm	1
24†	105510	WASHER, lock, spring (hi-collar)	12	181	240794	HOSE, coupled, 1/4 in. x 50 ft	1
25†		ARMATURE, clutch, 5 in.	1	308	108795	SCREW, mach, pnh	4
26†		HUB, armature	1	310	24A250	HANDLE, cart	1
27†		ROTOR, clutch, 5 in.	1	▲	16Y631	LABEL, warning	1
28†	101682	SCREW, cap, sch	4	▲	16Y632	LABEL, warning	1
29	287465	HOUSING, pinion, 5900	1	▲	16Y633	LABEL, warning	1
30	114672	WASHER, thrust	2	▲		CARD, Medical Alert	1
31	114699	WASHER, thrust	1		222385	English, French, Spanish	
32	287460	GEAR, combination, 5900	1		17A134	English, Chinese, Spanish	
33	287469	HOUSING, drive, 5900, <i>includes 33a, 33b</i>	1		17R476	English, Spanish, Portuguese	
33a	116192	WASHER, thrust	1				
33b	194173	WASHER	1				
34	116618	MAGNET	1				
35	112395	SCREW, cap, flng hd	1				
36	102962	SCREW, cap sch	4				
37	104008	WASHER, lock, spring	4				
38	15C753	SCREW, mach, hex wash hd	6				
39	119562	SWITCH, reed w/connector	1				
40★		HOUSING, bearing, 5900	1				
41★	17E789	SCREW, cap, socket head, SST	4				
42	106115	WASHER, lock (hi-collar)	4				
43	24V085	ROD, connecting, 5900	1				
44	16Y748	COVER, front, 5900, <i>includes 45</i>	1				
45★	118444	SCREW, mach, slot hex wash hd	5				
47	17H826	PUMP, displacement, 5900, <i>includes 86, 89, 90</i>	1				
68	244240	HOSE, coupled, <i>includes 69</i>	1				
69	241920	DEFLECTOR, threaded	1				
76	114678	BUSHING, strain relief	1				
79★	16X203	CLIP, drain line	1				
82	15V573	STRAINER, 1-11 1/2 NPSM, crushproof	1				
86	16Y579	FITTING	1				
87	16X904	HOSE, coupled	1				
89	248215	TUBE, intake	1				
90	118494	PACKING, o-ring	1				
98	125926	FITTING, 90 deg	1				
99	113161	SCREW, flange, hex hd	3				
108	114528	SCREW, mach, phillips, pnhd	2				
119	17E929	LABEL, brand, GMAX 5900	1				
120▲	15F638	LABEL, GMAX warning fire & skin	1				
121▲	194126	LABEL, warning	1				
122▲	290228	LABEL, caution	1				

▲ Replacement Danger and Warning Labels, Tags and Cards are available at no cost.

† Included in Clutch Replacement Kit 241113

★ Included in Bearing Housing Kit 24V088

## Part Specifications:

Ref.	Instruction
▲23	Torque clamp adjustment bolt to 140-160 in-lb (15.8-18.1 N•m) with reference 47 installed and ProConnect in locked position.
▲26	Torque to 40-45 in-lb (4.5-5.1 N•m)
▲27	Torque to 17-23 ft-lb (23.1-31.2 N•m)
▲28	Torque to 190-210 in-lb (21.5-23.7 N•m)
▲29	Torque to 115-135 in-lb (12.9-15.3 N•m)
▲30	Torque to 23-29 ft-lb (31.2-39.4 N•m)
▲31	Torque to 130-150 in-lb (14.7-16.9 N•m)
▲32	Torque to 30-45 in-lb (3.4-5.1 N•m)
▲33	Torque to 90-110 in-lb (10.2-12.4 N•m)
▲35	Torque to 8-12 in-lb (0.9-1.4 N•m)
▲37	Torque to 70-90 in-lb (7.9-10.2 N•m)
▲42	Torque to 170-190 in-lb (19.2-21.5 N•m)
▲43	Torque to 200-230 in-lb (22.6-25.9 N•m)

# GMAX II 5900 Convertible Series

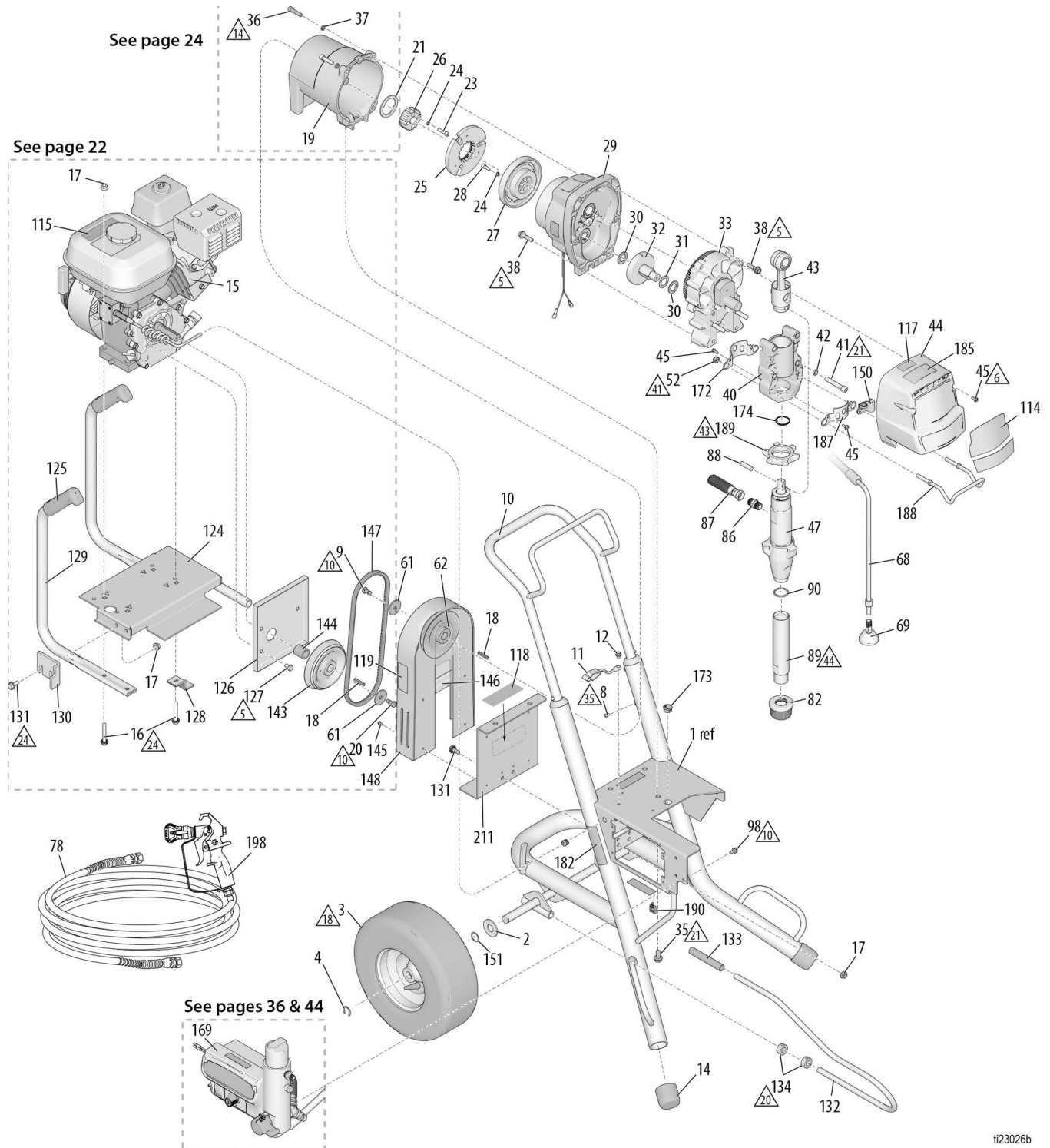

t23026b

## Parts List - GMAX II 5900 Convertible Series

Ref.	Part	Description	Qty.	Ref.	Part	Description	Qty.
1	19B275	FRAME, cart	1	134	198772	COLLAR, torsion bar	2
2	156306	WASHER, flat	2	142	119584	CORD, power, convertible	1
3	119509	WHEEL, pneumatic	2	145	100078	SCREW, thd forming, hex hd	4
4	15E891	CLIP, retaining	2	146	198996	BRACKET, belt guide	1
8	108795	SCREW, mach, pnh	4	147	193547	BELT, Vee, 30	1
9	121727	SCREW, cap, hex hd	1	148	198691	GUARD, belt	1
10	24A250	HANDLE, cart	1	150★	278204	CLIP, drain line	1
11	237686	WIRE, ground assembly w/ clamp	1	151	116038	WASHER, wave spring	2
12	112798	SCREW, thread forming, hex hd	1	155	15F354	FUNNEL, oil (not shown)	1
14	276974	CAP, leg	2	169	16X822	BOX, control	1
18	117632	KEY, square, 3/16	2	172	15C762	SHIELD, pump rod	1
19	287519	HOUSING, clutch	1	173	119569	BUSHING, strain relief	1
24*	105510	WASHER, lock, spring (hi-collar)	4	174	119778	SPRING, retaining	1
27*		ROTOR, clutch, 5 in.	1	182▲	15F638	LABEL, warning	1
28*	101682	SCREW, cap, sch	4	185	17E933	LABEL, series, GMAX, std	1
29	287465	HOUSING, pinion, 5900	1	187★	16X770	SHIELD, pump rod	1
30	114672	WASHER, thrust	2	188★	16C457	HANGER, pail	1
31	114699	WASHER, thrust	1	189	193031	NUT, retaining	1
32	287460	GEAR, combination	1	190	114687	CLIP, retainer	1
33	287700	HOUSING, drive, convert	1	198	17Y043	GUN, Contractor PC, RAC X	1
35	112395	SCREW, cap, flng hd	3	▲	16Y631	LABEL, warning	1
36	102962	SCREW, cap sch	4	▲	16Y632	LABEL, warning	1
37	104008	WASHER, lock, spring	4	▲	16Y633	LABEL, warning	1
38	15C753	SCREW, mach, torx, hex wash hd	6	▲		CARD, Medical Alert	
40★		HOUSING, bearing	1		222385	English, French, Spanish	
41★	17E789	SCREW, cap, socket head, SST	4		17A134	English, Chinese, Spanish	
42★	106115	WASHER, lock spring (hi-collar)	4		17R476	English, Spanish, Portuguese	
43	24V021	ROD, connecting	1				
44	16Y748	COVER, front; <i>includes 45</i>	1				
45★	118444	SCREW, machine hex washer head	8				
47	16Y706	PUMP, displacement, <i>includes 86, 89, 90</i>	1				
52★	111040	NUT, lock, insert, nylock, 5/16	2				
61	112717	WASHER	1				
62	198688	PULLEY, engine	1				
63	114425	BUSHING, strain relief	1				
68	244240	HOSE, coupled, <i>includes 69</i>	1				
69	241920	DEFLECTOR, threaded	1				
78	240794	HOSE, coupled, 1/4 in. x 50 ft	1				
82	189920	STRAINER, (1-11 1/2 npsm)	1				
86	196178	FITTING, pump	1				
87	16Y667	HOSE, coupled	1				
88	15F856	PIN, pump	1				
89†	248215	TUBE, intake	1				
90†	118494	O-RING	1				
91	122533	FITTING, 45 deg	1				
98	113161	SCREW, flange, hex hd	3				
114	17E931	LABEL, brand, GMAX 5900	1				
117▲	290228	LABEL, caution	1				
118▲	804495	LABEL, warning	1				
119	195098	LABEL, instruction (English)	1				
132	245688	BAR, torsion, <i>includes 133, 134</i>	1				
133	114808	CAP, vinyl	1				

▲ Replacement Danger and Warning labels, tags, and cards are available at no cost.

\* Included in Clutch Repair Kit 24113

★ Included in Bearing Housing Kit 24V027

### Part Specifications:

Ref.	Instruction
▲5	Torque to 190-210 in-lb (21.5-23.7 N•m)
▲6	Torque to 30-35 in-lb (3.4-3.9 N•m)
▲10	Torque to 115-135 in-lb (12.9-15.3 N•m)
▲14	Torque to 130-150 in-lb (14.7-16.9 N•m)
▲18	Inflate tires to 28-32 psi (1.93-2.21 bar/0.193-0.221 MPa)
▲20	Torque to 10-15 in-lb (1.1-1.7 N•m)
▲21	Torque to 20-30 ft-lb (27.1-40.1 N•m)
▲35	Torque to 25-35 in-lb (2.8-3.9 N•m)
▲41	Torque to 200-230 in-lb (22.5-25.9 N•m)
▲43	Torque to 75 +/- 5 ft-lb (101.6 +/- 6.7 N•m)
▲44	Torque to 70-90 in-lb (7.9-10.1 N•m)





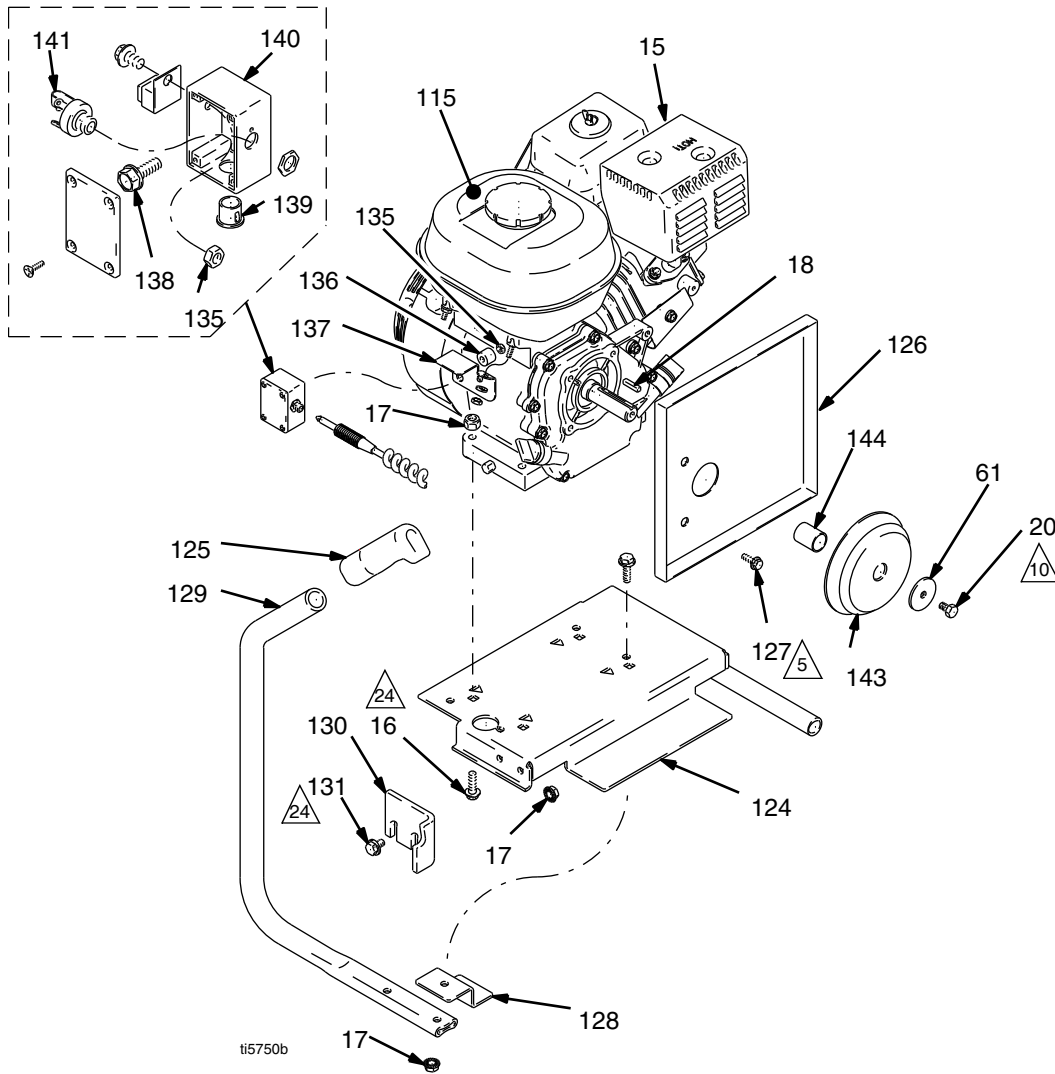



# GMAX II 5900 Convertible Series

## Engine Detail



# GMAX II 5900 Convertible Series

## Engine Detail - Parts List

Ref.	Part	Description	Qty.	Ref.	Part	Description	Qty.								
15	116080	ENGINE, gas, 6.5 Honda	1	136	116149	SPACER	1								
16	114653	SCREW, cap, flange hd	4	137	194414	BRACKET, J-box	1								
17	110996	NUT, flng hd, hex	6	138	114813	SCREW, mach, hex washer hd	1								
18	183401	KEY, parallel	1	139	114678	BUSHING, snap	1								
20	119717	SCREW, cap, hex hd	1	140	194181	BOX, junction, engine	1								
61	112717	WASHER	1	141	114805	JACK, 1/4 engine	1								
115	194126	LABEL, warning	1	143	15E896	PULLEY, engine	1								
124	245272	BASE, mounting	1	144	15B314	SLEEVE, motor shaft	1								
125	116139	GRIP, handle	2	<b>Part Specifications:</b>											
126	198689	BRACKET, belt guard (motor)	1	<table border="1"> <thead> <tr> <th>Ref.</th> <th>Instruction</th> </tr> </thead> <tbody> <tr> <td></td> <td>Torque to 190-210 in-lb (21.5-23.7 N•m)</td> </tr> <tr> <td></td> <td>Torque to 115-135 in-lb (12.9-15.3 N•m)</td> </tr> <tr> <td></td> <td>Torque to 17-23 ft-lb (23.0-31.1 N•m)</td> </tr> </tbody> </table>				Ref.	Instruction		Torque to 190-210 in-lb (21.5-23.7 N•m)		Torque to 115-135 in-lb (12.9-15.3 N•m)		Torque to 17-23 ft-lb (23.0-31.1 N•m)
Ref.	Instruction														
	Torque to 190-210 in-lb (21.5-23.7 N•m)														
	Torque to 115-135 in-lb (12.9-15.3 N•m)														
	Torque to 17-23 ft-lb (23.0-31.1 N•m)														
127	112406	SCREW	3												
128	198997	BRACKET, tension	1												
129	198693	HANDLE, slide, engine	2												
130	198695	BRACKET, torsion bar	1												
131	110963	SCREW, cap, hex hd, flange	2												
135	114816	NUT, hex	1												

## GMAX II 5900 Convertible Series

### Clutch Housing - Parts Drawing and List

Ref	Part	Description	Qty	Ref	Part	Description	Qty
19	287519	HOUSING, clutch, <i>includes 19b, 19c, 19e, 19j &amp; 19k</i>	1	24	105510*	WASHER, lock, spring (hi-collar)	8
19b	114962	RING, retaining, internal	1	25	*	ARMATURE, clutch, 5 in.	1
19c	287422	SHAFT, drive, input	1	26		HUB, armature	1
19e	15E887	HOUSING, clutch	1	27	*	ROTOR, clutch, 5 in.	1
19j	115078	O-RING	1	28	101682*	SCREW, cap, sch	4
19k	115079	O-RING	1	* Included in Clutch Repair Kit 241113			
21	15E894	STOP, armature	1				
23	108803*	SCREW, hex, socket head	4				

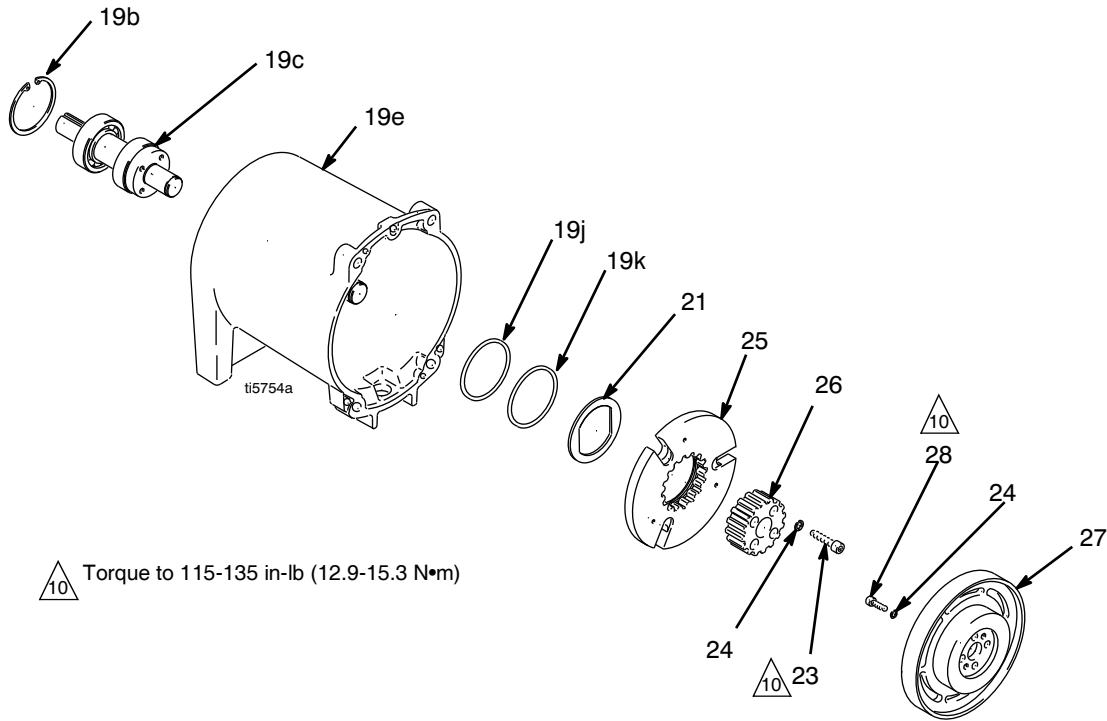



# GMAX II 7900 and 7900 HD Standard Series

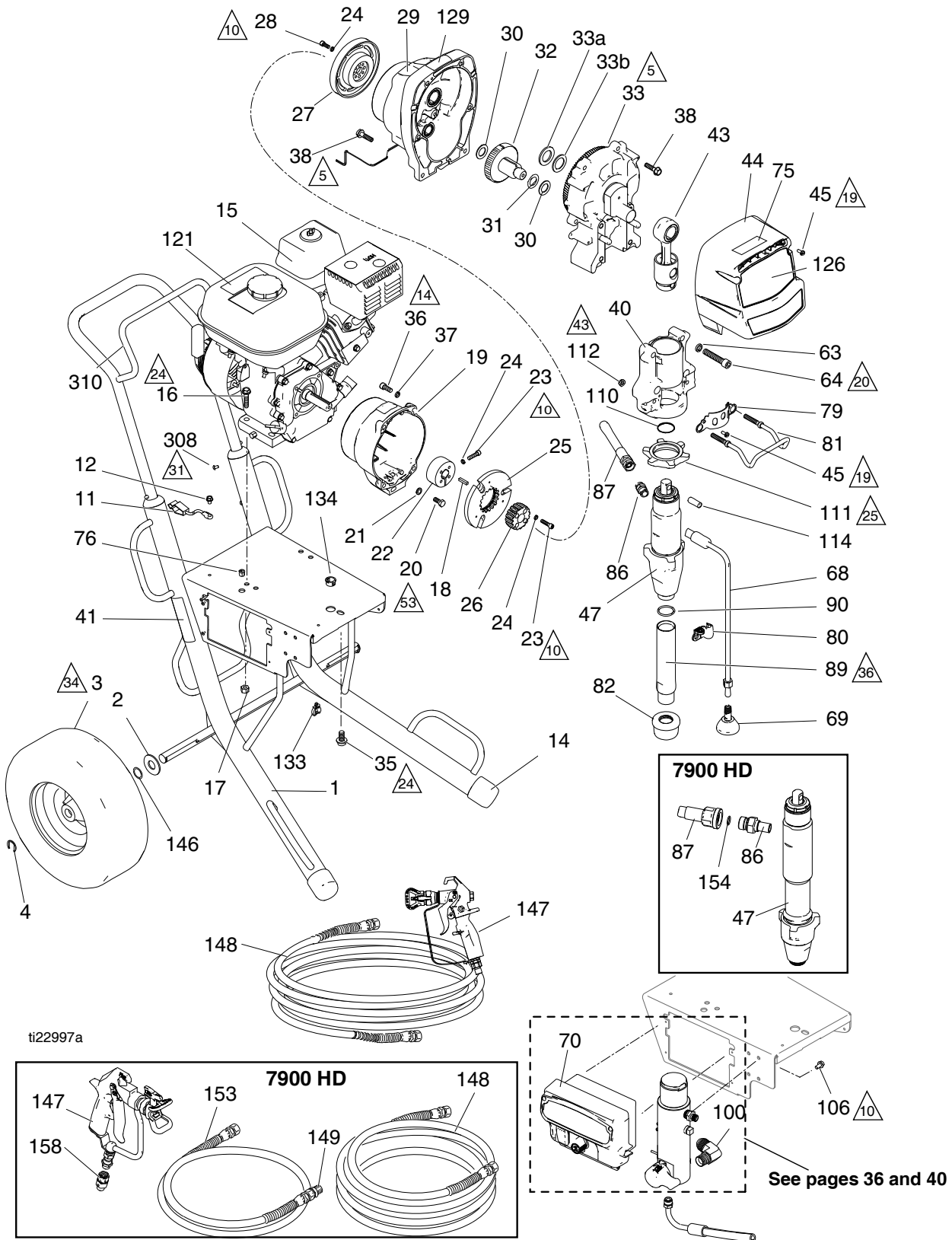

## Parts List - GMAX II 7900 and 7900 HD Standard Series

Ref.	Part	Description	Qty.	Ref.	Part	Description	Qty.
1	287370	FRAME	1	100	125926	FITTING, 90 deg	1
2	156306	WASHER, flat	2	106	113161	SCREW, flange, hex hd	3
3	119509	WHEEL, pneumatic	2	110	119677	SPRING, retaining	1
4	15E891	CLIP, retaining	2	111	193394	NUT, retaining	1
11	237686	WIRE, ground assembly w/ clamp	1	112	111040★	NUT, lock, insert, nylock, 5/16	2
12	112798	SCREW, thread forming, hex hd	1	114	19B144	PIN, pump	1
14	276974	CAP, leg	2	121▲	194126	LABEL, warning	1
15	116080	ENGINE, gas, 6.5 HP, Honda	1	126	17E930	LABEL, identification, 7900	1
16	110837	SCREW, flange, hex	2		17E937	LABEL, identification, 7900 HD	1
17	110838	NUT, lock	2	129▲	290228	LABEL, caution	1
18	183401	KEY, parallel	1	133	114687	CLIP, retainer	1
19	15E277	HOUSING, clutch, mach, 5900/7900	1	134	119569	BUSHING, strain relief	1
20	108842	SCREW, cap, hex hd	4	145	15F354	FUNNEL, oil (not shown)	1
21	100214	WASHER, lock	4	146	116038	WASHER, wave spring	2
22	193680	COLLAR, shaft	1	147	17Y043	GUN, Contractor PC, RAC X, 7900	1
23†	108803	SCREW, hex, socket head	6		241705	GUN, spray, texture, 7900 HD	1
24†	105510	WASHER, lock, spring	10	148	240794	HOSE, cpld, 1/4 in. x 50 ft., 7900	1
25†		ARMATURE, clutch, 5 in.	1		240797	HOSE, cpld, 3/8 in. x 50 ft., 7900 HD	1
26†		HUB, armature	1	149	159841	BUSHING, 7250 psi, 3/8 x 1/4 in., 7900 HD	1
27†		ROTOR, clutch, 5 in.	1	153	241735	HOSE, coupled, 1/4 in. x 3 ft, 7900 HD	1
28†	101682	SCREW, cap, sch	4	154	102982	O-RING, 7900 HD	1
29	287466	HOUSING, pinion, 7900	1	158	189018	SWIVEL, assembly, 7900 HD	1
30	114672	WASHER, thrust	2	308	108795	SCREW, mach, pnh	4
31	114699	WASHER, thrust	1	310	24A250	HANDLE, cart	1
32	287459	GEAR, combination, 7900	1		17H899	KIT, gauge, 1/4" (not shown)	1
33	287470	HOUSING, drive, 7900, <i>includes 33a,33b</i>	1		17H900	KIT, gauge, 3/8" (not shown)	1
33a	116192	WASHER, thrust	1	▲	16Y631	LABEL, warning	1
33b	194173	WASHER	1	▲	16Y632	LABEL, warning	1
35	112395	SCREW, cap, flng hd	1	▲	16Y633	LABEL, warning	1
36	102962	SCREW, cap sch	4	▲		CARD, Medical Alert	1
37	104008	WASHER, lock, spring	4		222385	English, French, Spanish	
38	15C753	SCREW, mach, hex wash hd	6		17A134	English, Chinese, Spanish	
40★		HOUSING, bearing, 7900	1		17R476	English, Spanish, Portuguese	
41▲	15F638	LABEL, GMAX warning fire & skin	1				
43	24V022	ROD, connecting, 7900	1				
44	16Y749	COVER, front, 7900 (includes 45)	1				
45★	118444	SCREW, mach, slot hex wash hd	6				
47	16X423	PUMP, displacement, 7900, <i>includes 86, 89, 90</i>	1				
	17H831	PUMP, displacement, 7900 HD, <i>includes 86</i>	1				
	25E689	PUMP, MAXLIFE, 7900 HD, <i>includes 86</i>	1				
63★	112600	WASHER, lock, spring	4				
64★	17E790	SCREW, cap, socket head, SST	4				
68	244240	HOSE, coupled, <i>includes 69</i>	1				
69	241920	DEFLECTOR, threaded	1				
70	16X822	BOX, control, standard	1				
75	17E933	LABEL, series, std	1				
76	114678	BUSHING, strain relief	1				
79★	16X770	SHIELD, pump rod	1				
80★	278204	CLIP, drain line	1				
81	16C457	HANGER, pail	1				
82	189920	STRAINER, (1-11 1/2 NPSM)	1				
86		FITTING, pump					
	196178	7900	1				
	16X835	7900 HD	1				
87		HOSE, coupled					
	16X909	7900	1				
	16X905	7900 HD	1				
89	248215	TUBE, intake, <i>includes 90</i>	1				
90	118494	PACKING, o-ring, 7900	1				

▲ Replacement Danger and Warning Labels, Tags and Cards are available at no cost.

† Included in Clutch Replacement Kit 241113

★ Included in Bearing Housing Kit 24V028

### Part Specifications:

Ref.	Instruction
5	Torque to 190-210 in-lb (21.5-23.7 N•m)
10	Torque to 115-135 in-lb (12.9-15.3 N•m)
14	Torque to 130-150 in-lb (14.7-16.9 N•m)
19	Torque to 30-35 in-lb (3.4-3.9 N•m)
20	Torque to 35-45 ft-lb (47.5-61.0 N•m)
24	Torque to 20 +/- 3 ft-lb (21.7 +/- 4.1 N•m)
25	Torque to 75 +/- 5 ft-lb (101.7 +/- 6.8 N•m)
31	Torque to 25-35 in-lb (2.8-3.9 N•m)
34	Inflate tires to 28-32 psi (1.93-2.21 bar/0.193-0.221 MPa)
36	Torque to 70-90 in-lb (7.9-10.2 N•m)
43	Torque to 200-230 in-lb (22.6-25.6 N•m)
53	Torque to 170-190 in-lb (19.2-21.5 N•m)



# Parts List - GMAX II 7900 and 7900 HD ProContractor Series

Ref.	Part	Description	Qty.	Ref.	Part	Description	Qty.
1	24D047	FRAME, hose reel	1	109	15F947	SHIELD, magnetic	1
2	156306	WASHER, flat	2	115	114528	SCREW, mach, phillips, pnhd	2
3	119509	WHEEL, pneumatic	2	121▲	194126	LABEL, warning	1
4	15E891	CLIP, retaining	2	126	17E930	LABEL, identification, 7900	1
5	16C381	TUBE, hydraulic, GMAX 5900/7900	1		17E937	LABEL, identification, 7900	
11	237686	WIRE, ground assembly w/ clamp	1	129	290228	LABEL, caution	1
12	112798	SCREW, thread forming, hex hd	1	133	114687	CLIP, retainer	1
14	276974	CAP, leg	2	134	119569	BUSHING, strain relief	1
15	116080	ENGINE, gas, 6.5 HP, Honda	1	143	15F354	FUNNEL, oil (not shown)	1
16	110837	SCREW, flange, hex	2	146	116038	WASHER, wave spring	2
17	110838	NUT, lock	2	149		O-RING	
18	183401	KEY, parallel	1		107505	7900	1
19	15E277	HOUSING, clutch, mach (5900/7900)	1		102982	7900 HD	1
20	108842	SCREW, cap, hex hd	4	171★	16X209	PLATE, front, ProConnect II	1
21	100214	WASHER, lock	4	172★	16X324	CLAMP, pump, large	1
22	193680	COLLAR, shaft	1	173★	101550	SCREW, cap, sch	2
23†	108803	SCREW, hex, socket head	6	174★	16C457	HANGER, pail	1
24†	105510	WASHER, lock, spring	12	175★	112746	NUT, lock, nylon, thin pattern	2
25†		ARMATURE, clutch, 5 in.	1	176	120583	NUT, hand, 7900 only	1
26†		HUB, armature	1	177	16X833	FITTING, quick disconnect, 3/8 npsm, 7900 only	1
27†		ROTOR, clutch, 5 in.	1		400 240797	HOSE, coupled, 3/8 in. x 50 ft, 7900 HD	1
28†	101682	SCREW, cap, sch	4	401	240794	HOSE, coupled, 1/4 in. x 50 ft, 7900	1
29	287466	HOUSING, pinion, 7900	1	403	241735	HOSE, coupled, 1/4 in. x 3 ft mx/f, 7900 HD	1
30	114672	WASHER, thrust	2	404	159841	BUSHING, 7250 psi, 3/8 x 1/4 in., 7900 HD	1
31	114699	WASHER, thrust	1	405	189018	SWIVEL	1
32	287459	GEAR, combination, 7900	1	▲	16Y631	LABEL, warning	1
33	287470	HOUSING, drive, 7900, <i>includes 33a, 33b</i>	1	▲	16Y632	LABEL, warning	1
33a	116192	WASHER, thrust	1	▲	16Y633	LABEL, warning	1
33b	194173	WASHER	1	▲		CARD, Medical Alert	
34	116618	MAGNET	1		222385	English, French, Spanish	
35	112395	SCREW, cap, flng hd	1		17A134	English, Chinese, Spanish	
36	102962	SCREW, cap sch	4		17R476	English, Spanish, Portuguese	
37	104008	WASHER, lock, spring	4				
38	15C753	SCREW, mach, hex wash hd	6				
39	119562	SWITCH, reed w/connector	1				
40★		HOUSING, bearing, 7900	1				
41▲	15F638	LABEL, GMAX warning fire & skin	1				
43	24V086	ROD, connecting, 7900	1				
44	16Y749	COVER, front, 7900, <i>includes 45</i>	1				
45★	118444	SCREW, mach, slot hex wash hd	5				
47	17H825	PUMP, displacement, 7900, <i>includes 86, 89, 90</i>	1				
	17H835	PUMP, displacement, 7900 HD, <i>includes 86</i>					
63★	112600	WASHER, lock, spring	4				
64★	17E790	SCREW, cap, socket head, SST	4				
68	244240	HOSE, coupled, <i>includes 69</i>	1				
69	241920	DEFLECTOR, threaded	1				
70	16X821	BOX, control	1				
75	17E934	LABEL, series, Pro	1				
76	114678	BUSHING, strain relief	1				
79★	16X203	CLIP, drain line	1				
81	17Y043	GUN, Contractor PC, RAC X, 7900	1				
	241705	GUN, spray, texture, 7900 HD	1				
82	15V573	STRAINER, 1-11 1/2 NPSM, crushproof	1				
86		FITTING, pump					
	16Y579	7900	1				
	16X835	7900 HD	1				
87		HOSE, coupled					
	16X904	7900	1				
	16X905	7900 HD	1				
89	248215	TUBE, intake, <i>includes 90</i>	1				
90	118494	PACKING, o-ring, 7900	1				
100	125926	FITTING, 90 deg	1				
106	113161	SCREW, flange, hex hd	3				
107	278083	GUIDE, hose	1				
108	117633	SCREW, slot hex wash hd	2				

▲ Replacement Danger and Warning Labels, Tags and Cards are available at no cost.

† Included in Clutch Replacement Kit 241113

★ Included in Bearing Housing Kit 24V089

## Part Specifications:

Ref.	Instruction
12	Inflate tires to 28-32 psi (1.93-2.21 bar/0.193-0.221 MPa)
23	Torque clamp adjustment bolt to 140-160 in-lb (15.8-18.1 N•m) with reference 47 installed and ProConnect in locked position.
24	Torque to 38-42 ft-lb (51.5-56.9 N•m)
25	Torque to 120-130 in-lb (13.4-14.7 N•m)
26	Torque to 40-45 in-lb (4.5-5.1 N•m)
27	Torque to 17-23 ft-lb (23.1-31.2 N•m)
28	Torque to 190-210 in-lb (21.5-23.7 N•m)
29	Torque to 115-135 in-lb (12.9-15.3 N•m)
30	Torque to 23-29 ft-lb (31.2-39.2 N•m)
31	Torque to 130-150 in-lb (14.7-16.9 N•m)
32	Torque to 30-45 in-lb (3.4-5.1 N•m)
33	Torque to 90-110 in-lb (10.2-12.4 N•m)
35	Torque to 8-12 in-lb (0.9-1.4 N•m)
37	Torque to 70-90 in-lb (7.9-10.2 N•m)
43	Torque to 170-190 in-lb (19.2-21.5 N•m)
45	Torque to 200-230 in-lb (22.6-25.9 N•m)

# GMAX II 7900 and 7900 HD IronMan Series / Roof Rig

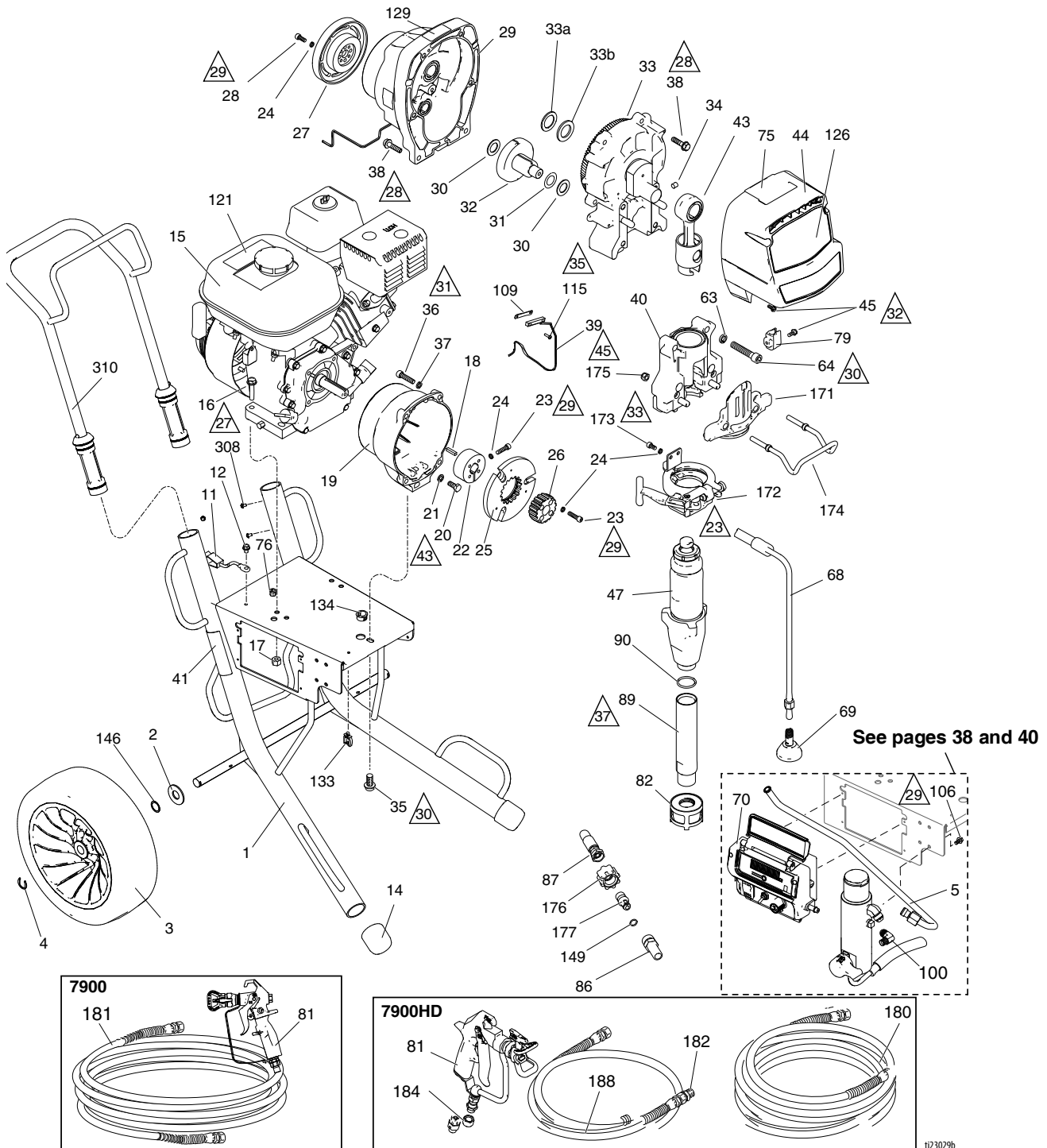

## Parts List - GMAX II 7900 and 7900 HD IronMan Series / Roof Rig

Ref.	Part	Description	Qty.	Ref.	Part	Description	Qty.	
1	287370	FRAME	1	109	15F947	SHIELD, magnetic	1	
2	156306	WASHER, flat	2	115	114528	SCREW, mach, phillips, pnhd	2	
3	17E687	WHEEL, flat proof, black, 13 in	2	121▲	194126	LABEL, warning	1	
4	120211	CLIP, retaining	2	126	17E930	LABEL, identification, 7900	1	
11	237686	WIRE, ground assembly w/ clamp	1		17E937	LABEL, identification, 7900 HD	1	
12	112798	SCREW, thread forming, hex hd	1	129	290228	LABEL, caution	1	
14	276974	CAP, leg	2	133	114687	CLIP, retainer	1	
15	116080	ENGINE, gas, 6.5 HP, Honda	1	134	119569	BUSHING, strain relief	1	
16	110837	SCREW, flange, hex	2	143	15F354	FUNNEL, oil (not shown)	1	
17	110838	NUT, lock	2	146	116038	WASHER, wave spring	2	
18	183401	KEY, parallel	1	149		O-RING		
19	15E277	HOUSING, clutch, mach, 5900/7900	1		107505	7900	1	
20	108842	SCREW, cap, hex hd	4		102982	7900 HD	1	
21	100214	WASHER, lock	4	171★	16X209	PLATE, front, ProConnect II	1	
22	193680	COLLAR, shaft	1	172★	16X324	CLAMP, pump, large	1	
23†	108803	SCREW, hex, socket head	6	173★	101550	SCREW, cap, sch	2	
24†	105510	WASHER, lock, spring	12	174★	16C457	HANGER, pail	1	
25†		ARMATURE, clutch, 5 in.	1	175★	112746	NUT, lock, nylon, thin pattern	2	
26†		HUB, armature	1	176	120583	NUT, hand, 7900 only	1	
27†		ROTOR, clutch, 5 in.	1	177	16X833	FITTING, quick disconnect, 3/8 npsm, 7900 only	1	
28†	101682	SCREW, cap, sch	4		180	240797	HOSE, coupled, 3/8 in. x 50 ft, 7900 HD	1
29	287466	HOUSING, pinion, 7900	1	181	240794	HOSE, coupled, 1/4 in. x 50 ft, 7900	1	
30	114672	WASHER, thrust	2	182	159841	BUSHING, 7250 psi, 3/8 in. x 1/4 in.	1	
31	114699	WASHER, thrust	1	184	189018	SWIVEL, assembly	1	
32	287459	GEAR, combination, 7900	1	187	164672	ADAPTER	1	
33	287470	HOUSING, drive, 7900, <i>includes 33a, 33b</i>	1	188	241735	HOSE, cpld, 1/4 in. x 3 ft, 7900 HD	1	
33a	116192	WASHER, thrust	1	308	108795	SCREW, mach, pnhd	4	
33b	194173	WASHER	1	310	24A250	HANDLE, cart	1	
34	116618	MAGNET	1	▲	16Y631	LABEL, warning	1	
35	112395	SCREW, cap, flng hd	1	▲	16Y632	LABEL, warning	1	
36	102962	SCREW, cap sch	4	▲	16Y633	LABEL, warning	1	
37	104008	WASHER, lock, spring	4	▲		CARD, Medical Alert		
38	15C753	SCREW, mach, hex wash hd	6		222385	English, French, Spanish		
39	119562	SWITCH, reed w/connector	1		17A134	English, Chinese, Spanish		
40★		HOUSING, bearing, 7900	1		17R476	English, Spanish, Portuguese		
41▲	15F638	LABEL, GMAX warning fire & skin	1					
43	24V086	ROD, connecting, 7900	1					
44	16Y749	COVER, front, 7900, <i>includes 45</i>	1					
45★	118444	SCREW, mach, slot hex wash hd	5					
47	17H827	PUMP, displacement, 7900, <i>includes 86, 89, 90</i>	1					
	17H837	PUMP, displacement, 7900 HD, <i>includes 86</i>						
63★	112600	WASHER, lock, spring	4					
64★	17E790	SCREW, cap, socket head, SST	4					
68	244240	HOSE, coupled, <i>includes 69</i>	1					
69	241920	DEFLECTOR, threaded	1					
70	16X821	BOX, control	1					
75	17E935	LABEL, series, Ironman	1					
76	114678	BUSHING, strain relief	1					
79★	16X203	CLIP, drain line	1					
81	17Y043	GUN, Contractor PC, RAC X, 7900	1					
	241705	GUN, spray, texture, 7900 HD	1					
82	15V573	STRAINER, 1-11 1/2 NPSM, crushproof	1					
86		FITTING, pump						
	16Y579	7900	1					
	16X835	7900 HD	1					
87		HOSE, coupled						
	16X904	7900	1					
	16X905	7900 HD	1					
89	248215	TUBE, intake, <i>includes 90</i>	1					
90	118494	PACKING, o-ring, 7900	1					
100	125926	FITTING, 90 deg	1					
106	113161	SCREW, flange, hex hd	3					

▲ Replacement Danger and Warning Labels, Tags and Cards are available at no cost.

† Included in Clutch Replacement Kit 241113

★ Included in Bearing Housing Kit 24V089

### Part Specifications:

Ref.	Instruction
▲ <sub>23</sub>	Torque clamp adjustment bolt to 140-160 in-lb (15.8-18.1 N•m) with reference 47 installed and ProConnect in locked position.
▲ <sub>27</sub>	Torque to 17-23 ft-lb (23.1-31.2 N•m)
▲ <sub>28</sub>	Torque to 190-210 in-lb (21.5-23.7 N•m)
▲ <sub>29</sub>	Torque to 115-135 in-lb (12.9-15.3 N•m)
▲ <sub>30</sub>	Torque to 23-29 ft-lb (31.2-39.3 N•m)
▲ <sub>31</sub>	Torque to 130-150 in-lb (14.7-16.9 N•m)
▲ <sub>32</sub>	Torque to 30-45 in-lb (3.4-5.1 N•m)
▲ <sub>33</sub>	Torque to 90-110 in-lb (10.2-12.4 N•m)
▲ <sub>35</sub>	Torque to 8-12 in-lb (0.9-1.4 N•m)
▲ <sub>37</sub>	Torque to 70-90 in-lb (7.9-10.2 N•m)
▲ <sub>43</sub>	Torque to 170-190 in-lb (19.2-21.5 N•m)
▲ <sub>45</sub>	Torque to 200-230 in-lb (22.5-25.9 N•m)

# GMAX II 7900 Lo-Boy Series

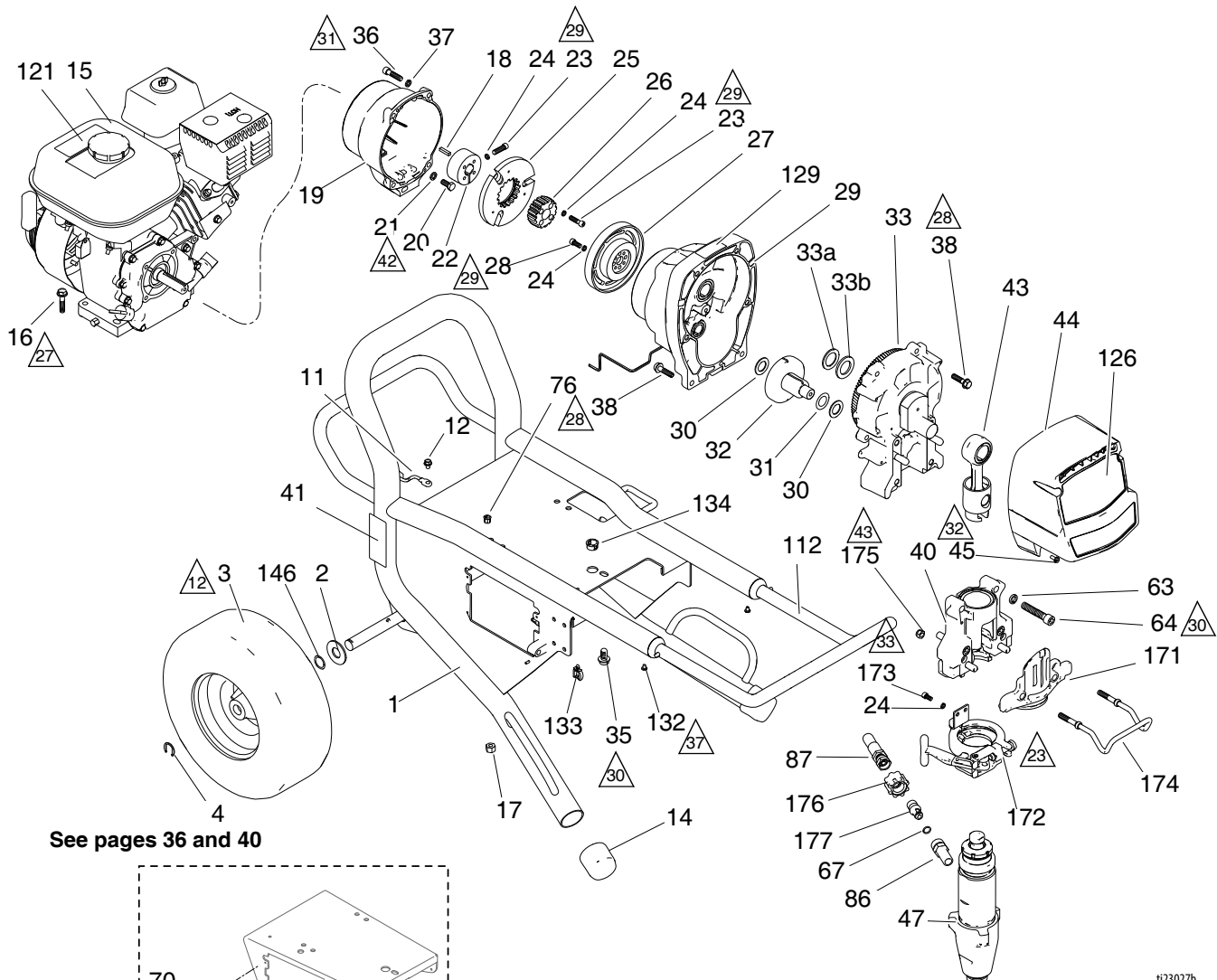

See pages 36 and 40

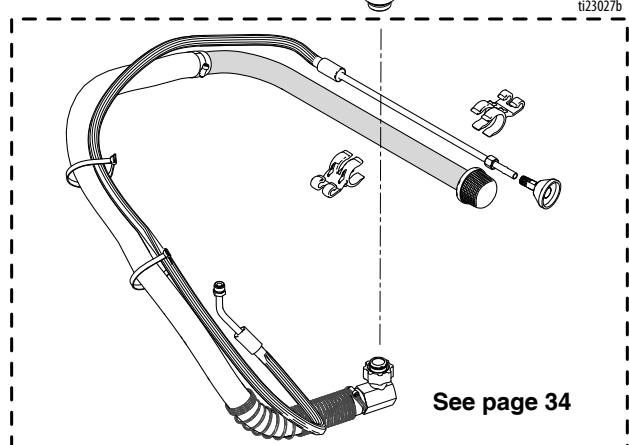
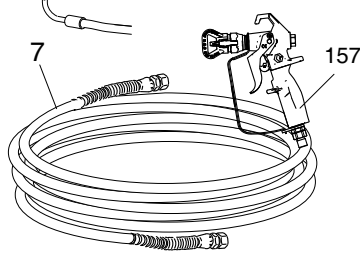
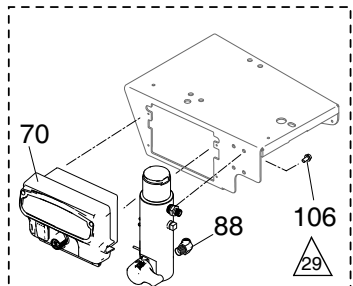

See page 34

## Parts List - GMAX II 7900 Lo-Boy Series

Ref.	Part	Description	Qty.	Ref.	Part	Description	Qty.
1	16Y519	FRAME	1	88	122533	FITTING, 45 deg	1
2	156306	WASHER, flat	2	106	113161	SCREW, flange, hex hd	3
3	119509	WHEEL, pneumatic	2	112	16Y780	HANDLE, cart	1
4	15E891	CLIP, retaining	2	121▲	194126	LABEL, warning	1
7	240794	HOSE, coupled, 1/4 in. x 50 ft	1	126	17E930	LABEL, brand, GMAX 7900	1
11	237686	WIRE, ground assembly w/ clamp	1	129	290228	LABEL, caution	1
12	112798	SCREW, thread forming, hex hd	1	132	109032	SCREW, mach, pnh	4
14	276974	CAP, leg	2	133	114687	CLIP, retainer	1
15	116080	ENGINE, gas, 6.5 HP, Honda	1	134	119569	BUSHING, strain relief	1
16	110837	SCREW, flange, hex	2	146	116038	WASHER, wave spring	2
17	110838	NUT, lock	2	157	17Y043	GUN, Contractor PC, RAC X	1
18	183401	KEY, parallel	1	171★	16X209	PLATE, front, ProConnect II, 7900	1
19	15E277	HOUSING, clutch, 5900/7900	1	172★	16X324	CLAMP, pump, large	1
20	108842	SCREW, cap, hex hd	4	173★	101550	SCREW, cap, sch	2
21	100214	WASHER, lock	4	174★	16C457	HANGER, pail	1
22	193680	COLLAR, shaft	1	175★	112746	NUT, lock, nylon, thin pattern	2
23†	108803	SCREW, hex, socket head	6	176	120583	NUT, hand	1
24†	105510	WASHER, lock, spring	12	177	16X833	FITTING, quick disconnect, 3/8 npsm	1
25†		ARMATURE, clutch, 5 in.	1		17H899	KIT, gauge, 1/4" (not shown)	1
26†		HUB, armature	1	▲	16Y631	LABEL, warning	1
27†		ROTOR, clutch, 5 in.	1	▲	16Y632	LABEL, warning	1
28†	101682	SCREW, cap, sch	4	▲	16Y633	LABEL, warning	1
29	287466	HOUSING, pinion, 7900	1				
30	114672	WASHER, thrust	2				
31	114699	WASHER, thrust	1				
32	287459	GEAR, combination, 7900	1				
33	287470	HOUSING, drive, 7900, <i>includes 33a, 33b</i>	1				
33a	116192	WASHER, thrust	1				
33b	194173	WASHER	1				
35	112395	SCREW, cap, flng hd	1				
36	102962	SCREW, cap sch	4				
37	104008	WASHER, lock, spring	4				
38	15C753	SCREW, mach, hex wash hd	6				
40★		HOUSING, bearing	1				
41▲	15F638	LABEL, GMAX warning fire & skin	1				
43	24V086	ROD, connecting, 7900	1				
44	16Y749	COVER, front, 7900, <i>includes 45</i>	1				
45★	118444	SCREW, mach, slot hex wash hd	4				
47	17H825	PUMP, displacement, 7900, <i>includes 86, 89, 90</i>	1				
63★	112600	WASHER, lock, spring	4				
64★	17E790	SCREW, cap, socket head, SST	4				
67	107505	O-RING	1				
70	16X822	BOX, control	1				
76	114678	BUSHING, strain relief	1				
86	16Y579	FITTING, pump	1				
87	16X950	HOSE, coupled	1				

▲ *Replacement Danger and Warning Labels, Tags and Cards are available at no cost.*

† *Included in Clutch Replacement Kit 241113*

★ *Included in Bearing Housing Kit 24V089*

*Suction Kit 16Y760 Kit is available*

### Part Specifications:

Ref.	Instruction
▲2	Inflate tires to 28-32 psi (1.93-2.21 bar/0.193-0.221 MPa)
▲3	Torque clamp adjustment bolt to 140-160 in-lb (15.8-18.1 N•m) with reference 47 installed and ProConnect in locked position.
▲7	Torque to 17-23 ft-lb (23.1-31.2 N•m)
▲8	Torque to 190-210 in-lb (21.5-23.7 N•m)
▲9	Torque to 115-135 in-lb (12.9-15.3 N•m)
▲0	Torque to 23-29 ft-lb (31.2-39.3 N•m)
▲1	Torque to 130-150 in-lb (14.7-16.9 N•m)
▲2	Torque to 30-45 in-lb (3.4-5.1 N•m)
▲3	Torque to 90-110 in-lb (10.2-12.4 N•m)
▲7	Torque to 25-35 in-lb (2.8-3.9 N•m)
▲2	Torque to 170-190 in-lb (19.2-25.9 N•m)
▲3	Torque to 200-230 in-lb (22.5-25.9 N•m)

# LoBoy Suction Set Kits

(Kits include suction set and drain hose)

## GMAX II 3900/5900/7900

5 Gallon Kit: 16Y759 (included with 3900 and 5900)

30 - 55 Gallon Kit: 16Y760 (included with 7900)

Ref.	Part	Description	Qty.
509	24W028	HOSE, suction 5 gallon, <i>includes 510, 511, 512, 514, 557, 558, 559, 561</i>	1
	24U917	HOSE, suction 30 - 55 gallon, <i>includes 510, 511, 512, 514, 557, 558, 559, 561</i>	1
510	15C980	NUT, jam	1
511	15H854	O-RING	2
512	15C981	WASHER, suction, swivel	1
514	118505	RING, retaining, external	1
515	15D000	CLIP, drain line	2
555	241920	DEFLECTOR	1
556	288732	5 gallon	1
	246331	30 - 55 gallon	1
557		TUBE, suction	
	15D157	5 gallon	1
	15F171	30 - 50 gallon	1
558	24A561	FITTING, elbow, barbed, <i>includes 510, 512, 514</i>	1
559	120330	CLAMP, hose	2
561	176450	GUARD, hose	1
582	189920	STRAINER, 1-11 1/2 npsm	1
586		Washer	1
	115099	3900/5900	
	119566	7900	
591		TIE STRAP	2

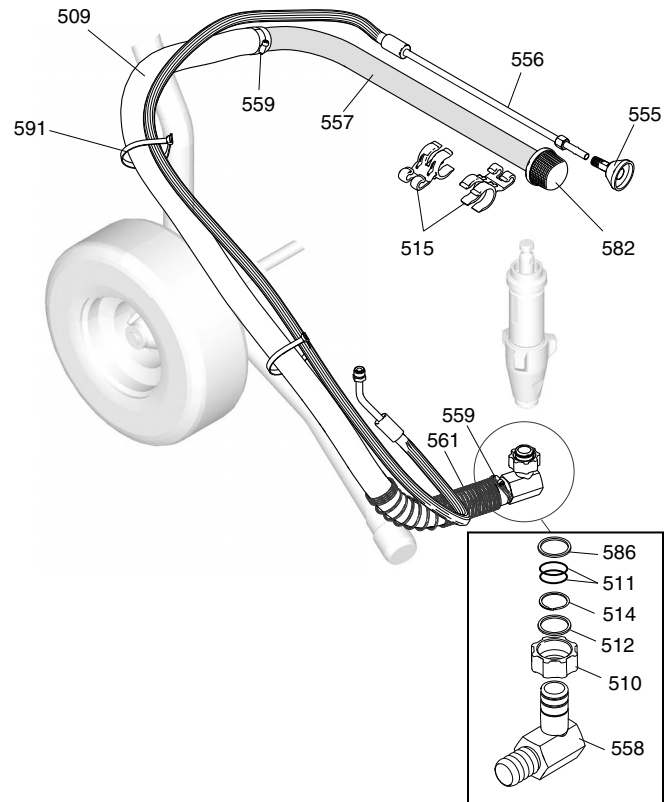

# Control Box 25P549 - GMAX 3400

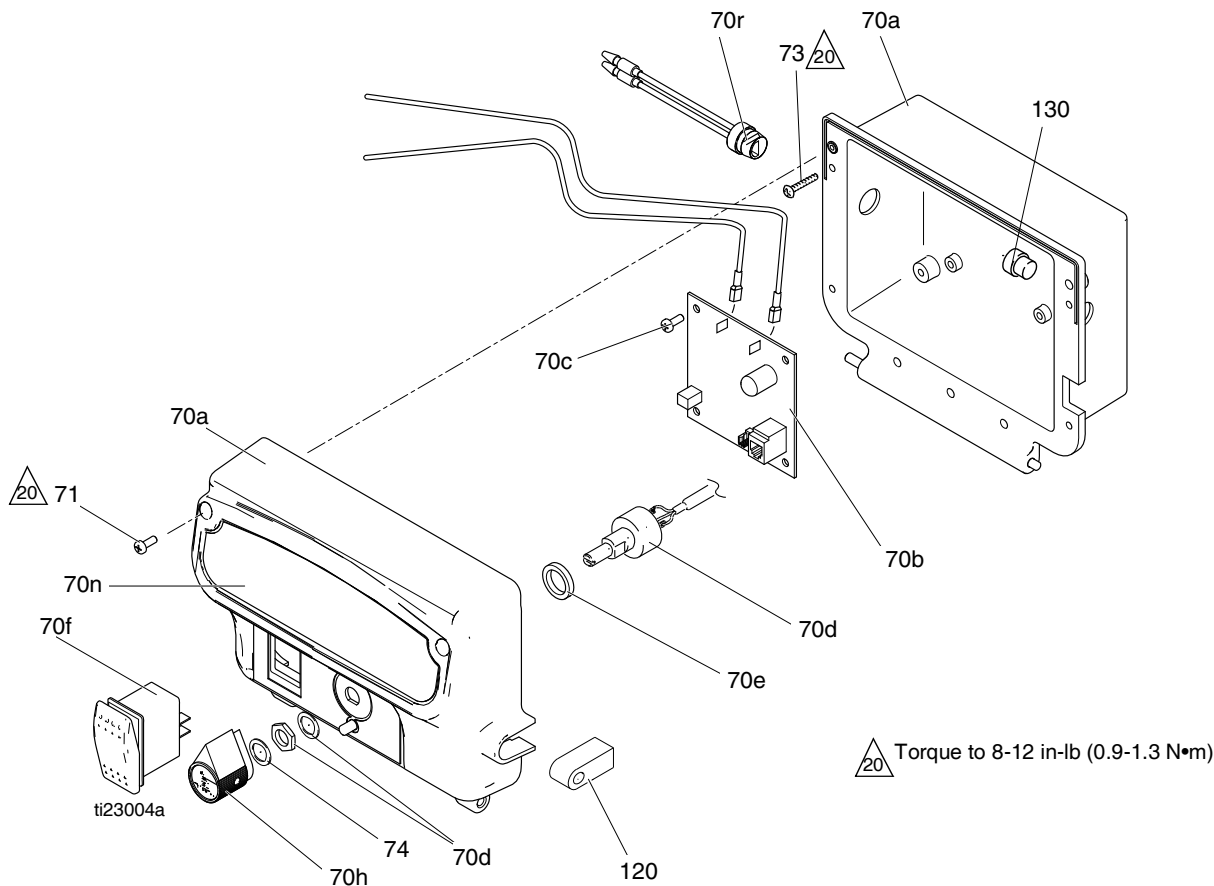

## Parts List - Control Box 25P549

Ref.	Part	Description	Qty.	Ref.	Part	Description	Qty.
70	25P549	CONTROL BOX, GMAX 3400		70r	119545	BUSHING, strain, relief	1
70a	24U346	BOX	1	71	116585	SCREW, pan, X recess, sst	2
70b	25P550	KIT, repair, control board	1	73	116585	SCREW, pan, X recess, sst (5900 Convertible)	4
70c	117317	SCREW, plastite, pan head	4		113160	SCREW, mach, slot, hex wash hd	4
70d	256219	POTENTIOMETER	1	74	15C973	GASKET	1
70e	198650	SPACER, shaft	1	120	16Y415	GASKET, transducer	1
70f	116752	SWITCH, rocker	1	130	119545	BUSHING, strain, relief	1
70h	116167	KNOB, potentiometer	1				
70n	16Y782	LABEL, brand	1				

# Control Box 16X822 - Standard & Lo-Boy Series

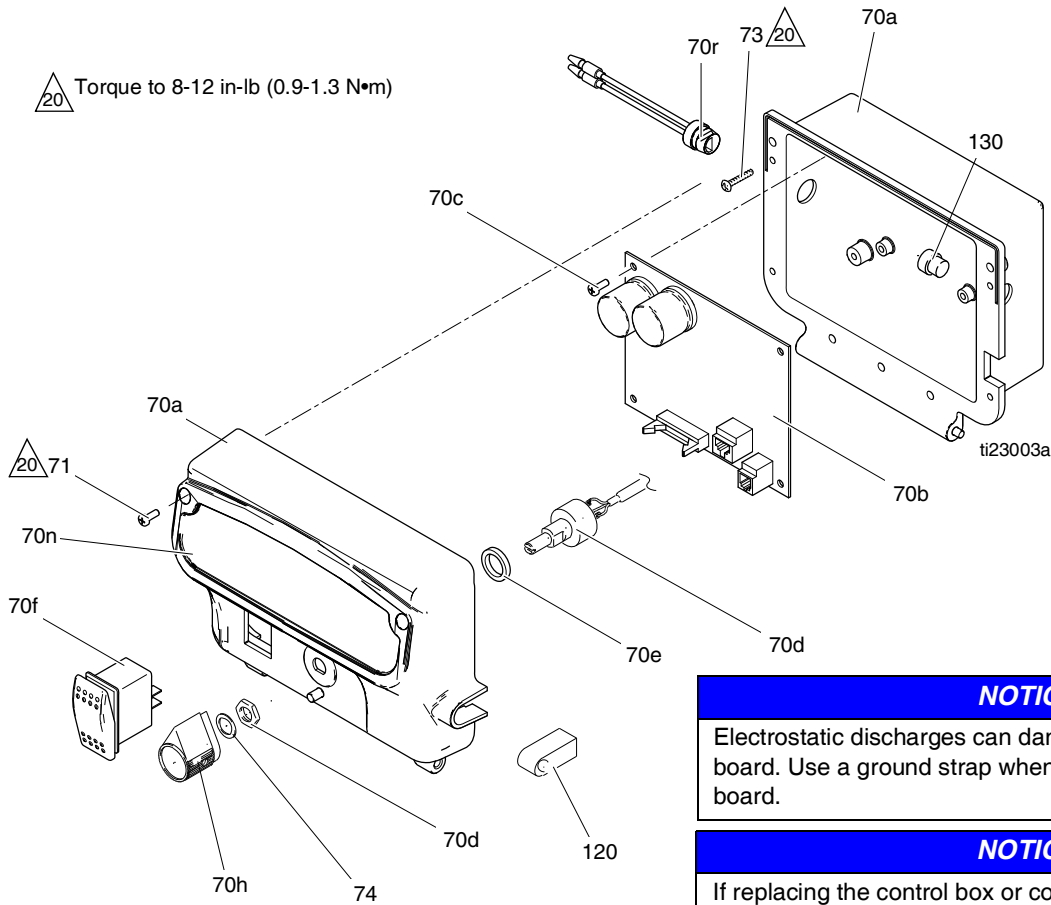

**NOTICE**  
Electrostatic discharges can damage components on PC board. Use a ground strap when handling or installing PC board.

**NOTICE**  
If replacing the control box or control board, cut out and remove the resistor(s) on control board according to figure and table. Using configurations other than those listed results in poor sprayer performance.

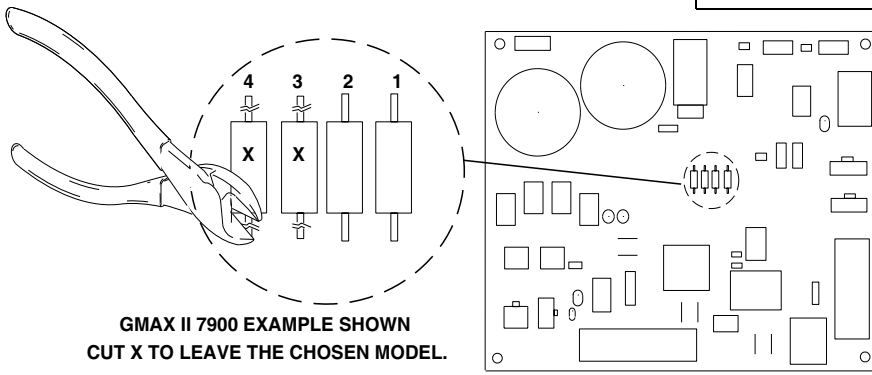



	3900	5900		7900
	GMAX II 3900	GMAX II 5900/5900 HD	GMAX II 5900 Convertible	GMAX II 7900/7900 HD
1	X			
2		X		
3		X		X
4			X	X

# Parts List - Control Box 16X822

Ref.	Part	Description	Qty.	Ref.	Part	Description	Qty.
70	16X822	CONTROL BOX		70r	119545	BUSHING, strain, relief	1
70a	24U346	BOX	1	71	116585	SCREW, pan, X recess, sst	2
70b	17A095	CONTROL, board	1	73	116585	SCREW, pan, X recess, sst (5900 Convertible)	4
70c	117317	SCREW, plastite, pan head	4		113160	SCREW, mach, slot, hex wash hd	4
70d	256219	POTENTIOMETER	1				
70e	198650	SPACER, shaft	1	74	15C973	GASKET	1
70f	116752	SWITCH, rocker	1	120	16Y415	GASKET, transducer	1
70h	116167	KNOB, potentiometer	1	130	119545	BUSHING, strain, relief	1
70n	16Y782	LABEL, brand	1				

# Control Box 16X821 - ProContractor & Ironman Series

 Torque to 3-4 in-lb (0.4-0.5 N•m)

 Torque to 8-12 in-lb (0.9-1.3 N•m)

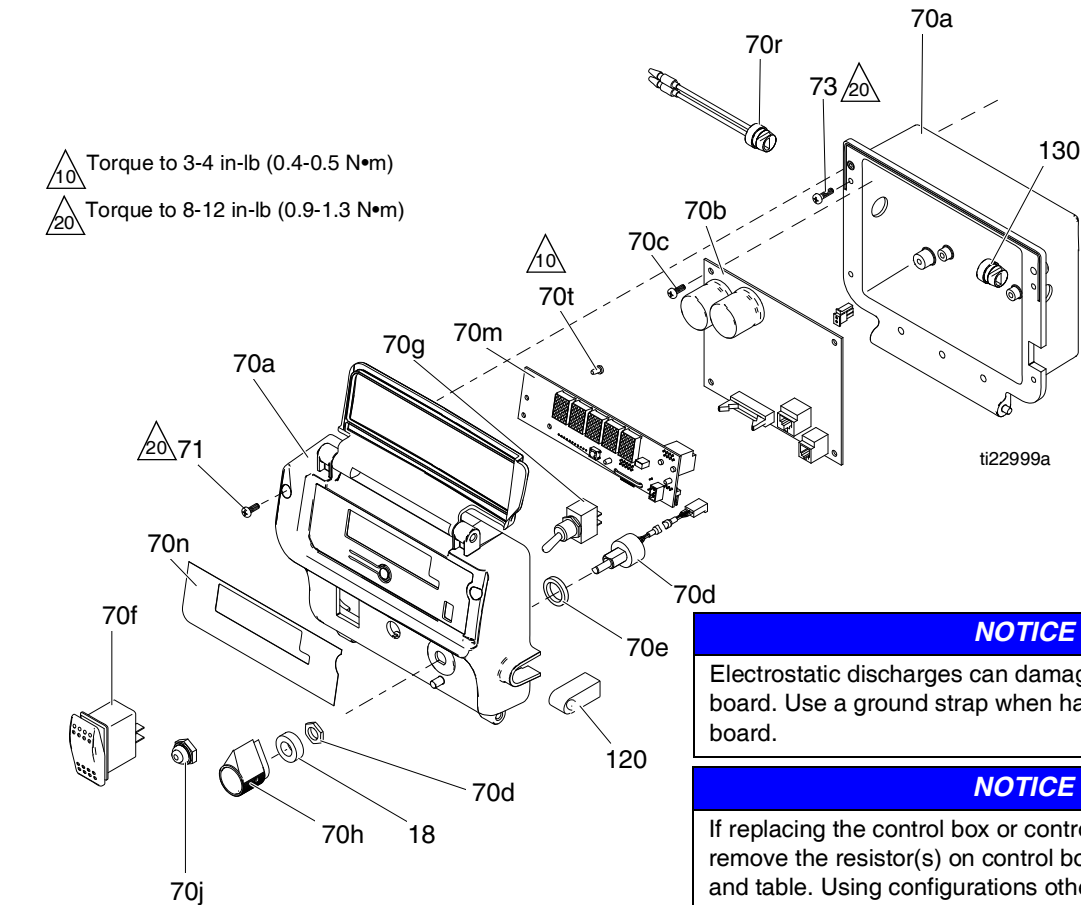

**NOTICE**

Electrostatic discharges can damage components on PC board. Use a ground strap when handling or installing PC board.

**NOTICE**

If replacing the control box or control board, cut out and remove the resistor(s) on control board according to figure and table. Using configurations other than those listed results in poor sprayer performance.

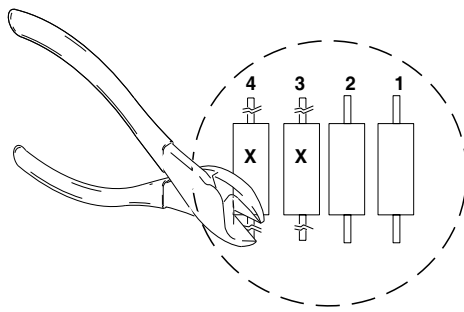

GMAX II 7900 EXAMPLE SHOWN  
CUT X TO LEAVE THE CHOSEN MODEL.

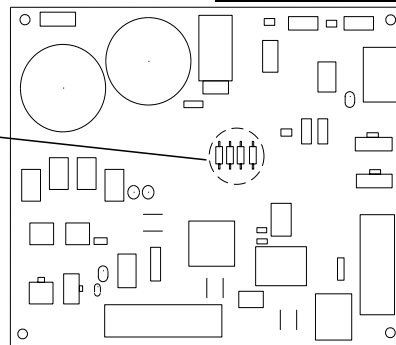

	3900	5900		7900
	GMAX II 3900	GMAX II 5900/5900 HD	GMAX II 5900 Convertible	GMAX II 7900/7900 HD
1	X			
2		X		
3		X		X
4			X	X

## Parts List - Control Box 16X821

Ref.	Part	Description	Qty.	Ref.	Part	Description	Qty.
18	15C973	GASKET	1	70j	195428	BOOT, toggle	1
70	16X821	CONTROL BOX		70m	16Y496	KIT, display, <i>includes 70t</i>	1
70a	24U347	BOX	1	70n	16X801	LABEL, brand	1
70b	17A095	CONTROL, board	1	70r	119545	BUSHING, strain, relief	1
70c	117317	SCREW, plastite, pan head	4	70t	115522	SCREW, mach, pnh	3
70d	256219	POTENTIOMETER	1	71	116585	SCREW, pan, X recess, sst	2
70f	116752	SWITCH, rocker	1	73	113160	SCREW, mach, slot, hex wash hd	4
70e	198650	SPACER, shaft	1	120	16Y415	GASKET, transducer	1
70g	119541	SWITCH, toggle	1	130	119545	BUSHING, strain, relief	1
70h	116167	KNOB, potentiometer	1				

# Filter

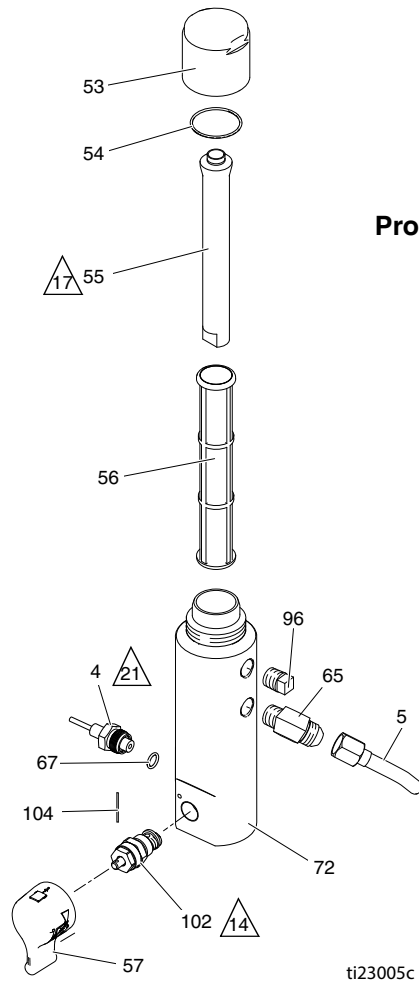
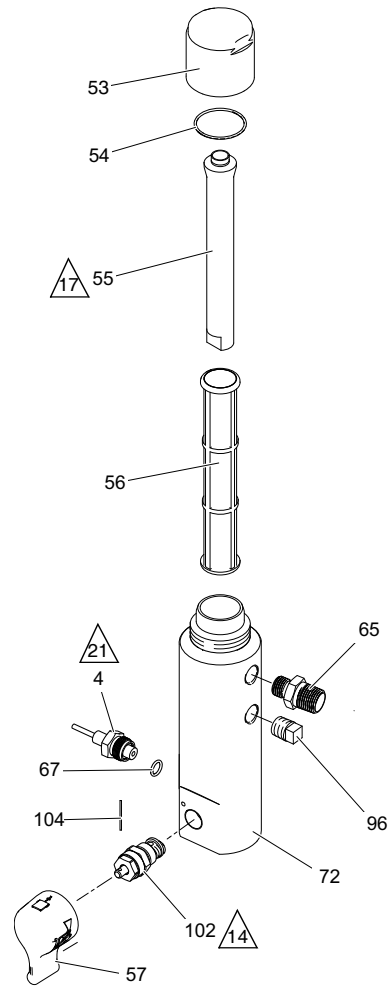

**ProContractor Only**

ti23005c

## Parts List - Filter

Ref.	Part	Description	Qty.
4	243222	TRANSDUCER, pressure control <i>includes 63</i>	1
5	16C381	TUBE, GMAX 5900/7900 (ProContractor)	1
	16C384	TUBE, GMAX 3900 (ProContractor)	1
53	287285	CAP, filter, <i>includes 54, 55</i>	1
54	117285	PACKING, o-ring	1
55	15C766	TUBE, diffusion	1
56	244067	FILTER, fluid	1
57	24E234	KIT, handle 2 position	1
65	122533	FITTING, 45 deg elbow (ProConnect)	1
	196177	FITTING, adapter (GMAX Standard/ Convertible/Lo-Boy/Ironman)	1
	196178	FITTING, adapter (HD Standard/Ironman)	1

Ref.	Part	Description	Qty.
67	111457	PACKING, o-ring	1
72	15E284	HOUSING, filter	1
96	15G331	PLUG, pipe, 3/8-18	1
102	257352	VALVE, prime, heavy duty, <i>includes 57, 104</i>	1
104	15C972	PIN, spring	1

### Part Specifications:

Ref.	Instruction
14	Torque to 130-150 in-lb (14.6-16.9 N•m)
17	Torque to 90-110 in-lb (10.1-12.4 N•m)
21	Torque to 35-45 ft-lb (47.4-61.0 N•m)

# Filter (3400 Models only)

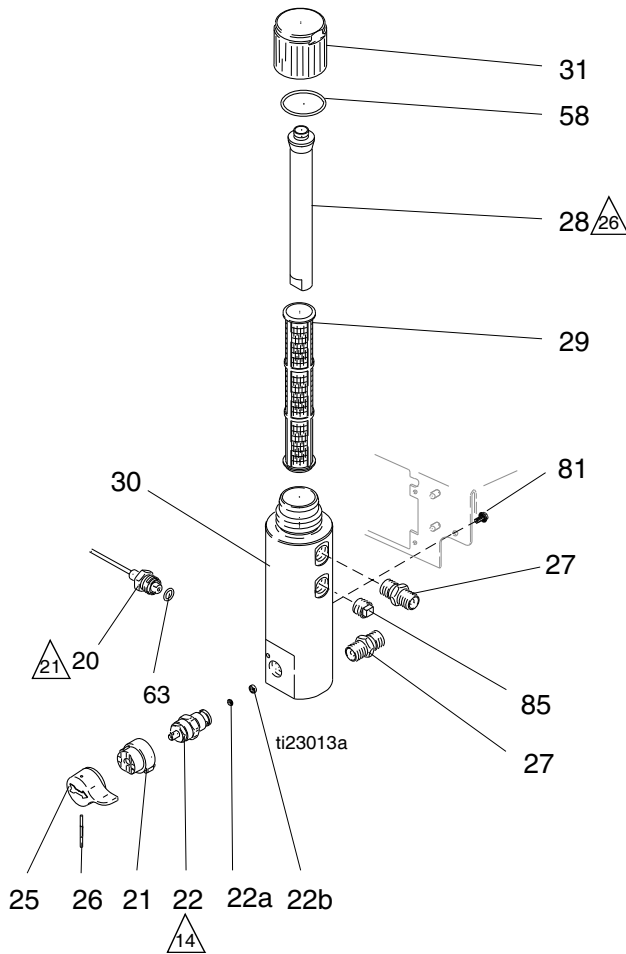

## Parts List - Filter

Ref.	Part	Description	Qty.
20	243222	TRANSDUCER, pressure control, includes 63	1
21	224807	BASE, valve	1
22	235014	VALVE, drain, includes 22a, 22b	1
25	15C780	HANDLE,	1
26	15C972	PIN, grooved	1
27	196177	NIPPLE, adapter	2
28	15C766	TUBE, diffusion	1
29	244067	FILTER, fluid	1
30	15E284	HOUSING, filter	1

Ref.	Part	Description	Qty.
31	287285	CAP, filter, includes 28, 58	1
58	117285	O-RING	1
63	111457	O-RING	1
81	113161	SCREW, flange, hex hd	3
85	15G331	PLUG, pipe	1

### Part Specifications:

Ref.	Instruction
△14	Torque to 130-150 in-lb (14.6-16.9 N•m)
△21	Torque to 35-45 ft-lb (47.4-61.0 N•m)
△26	Torque to 90-110 in-lb (10.1-12.4 N•m)

# QuikReel™ (ProContractor Sprayers)

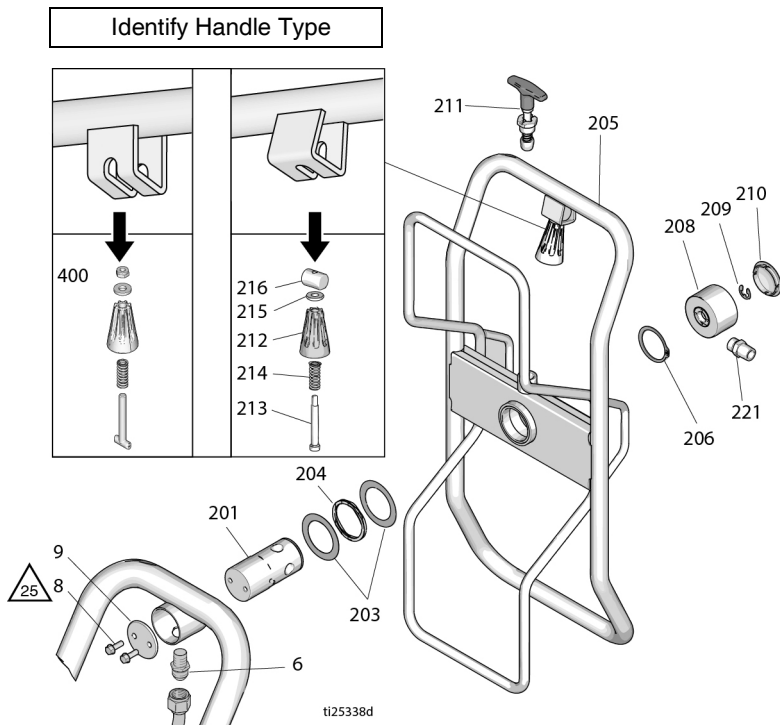

## Parts List - Hose Reel (ProContractor Sprayers)

Ref.	Part	Description	Qty.	Ref.	Part	Description	Qty.
6	121311	FITTING, connector, NPT x JIC	1	213	122518	SCREW, shoulder, sch	1
8	260212	SCREW, hex washer hd	2	214	122542	SPRING, die	1
9	16C975	PLATE, pivot mount	1	215	122669	WASHER, flat	1
201	24E016	TUBE, hose reel, pivot	1	216	15X618	NUT, swivel, handle	1
203	122607	WASHER, flat	2	221	164672	ADAPTER, GMAX	1
204	122534	SPRING, wave	1		162485	ADAPTER, HD	1
205*	2009286	KIT, hose reel	1	400	2009285	KIT, handle	1
206	122524	RING, retaining, external	1	* Includes 2009285			
208	24B248	CAP, swivel, complete	1	 Torque to 120-130 in-lb (13.5-14.6 N·m)			
209	122347	RING, retaining, external	1				
210	122787	CAP	1				
211	24E400	PIN, pop, lock out	1				
212	278085	HANDLE, swivel	1				



# Pressure Control Wiring Diagrams

## GMAX 3400 Sprayers

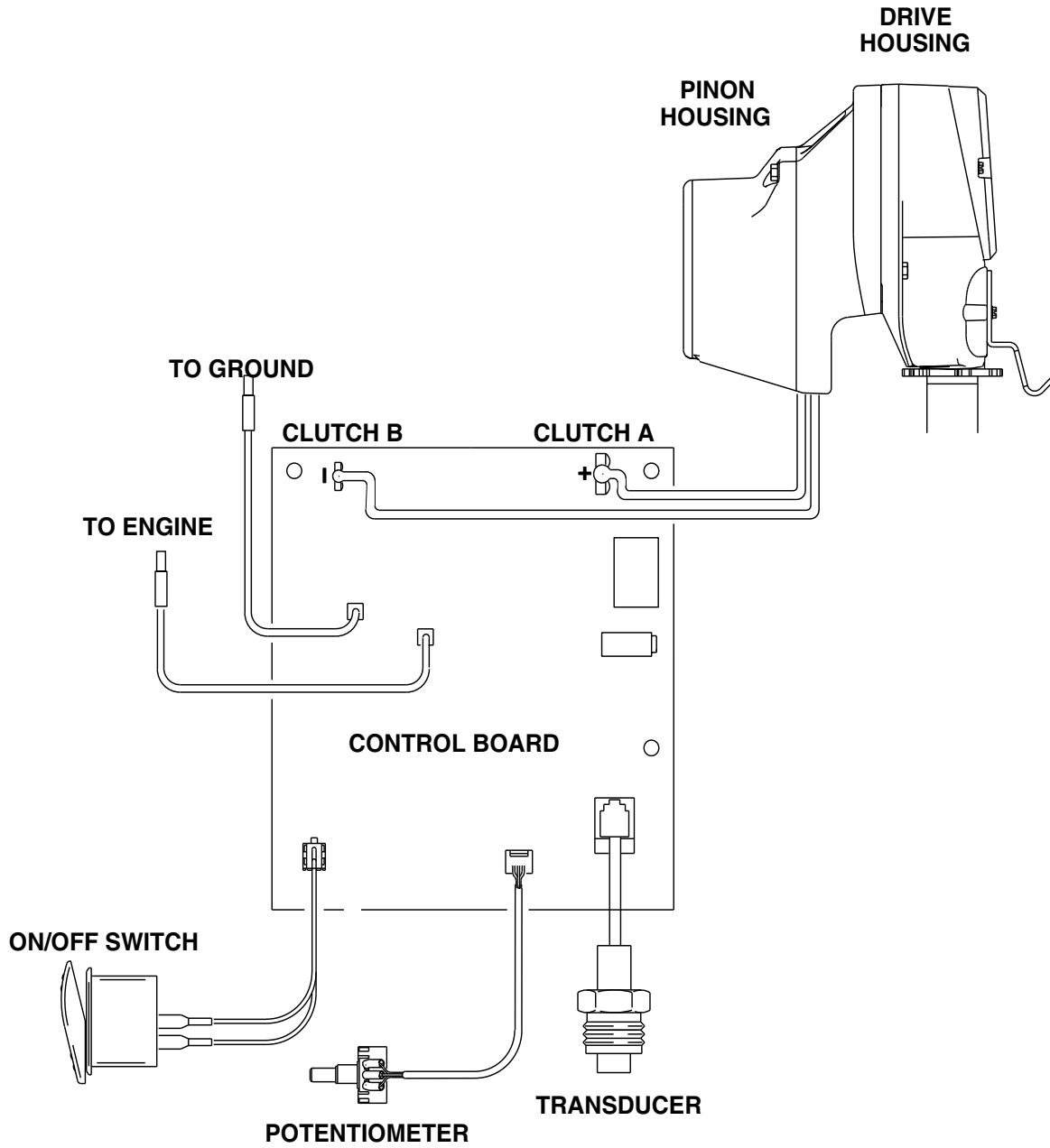





# Graco Standard Warranty

Graco warrants all equipment referenced in this document which is manufactured by Graco and bearing its name to be free from defects in material and workmanship on the date of sale to the original purchaser for use. With the exception of any special, extended, or limited warranty published by Graco, Graco will, for a period of twelve months from the date of sale, repair or replace any part of the equipment determined by Graco to be defective. This warranty applies only when the equipment is installed, operated and maintained in accordance with Graco's written recommendations.

This warranty does not cover, and Graco shall not be liable for general wear and tear, or any malfunction, damage or wear caused by faulty installation, misapplication, abrasion, corrosion, inadequate or improper maintenance, negligence, accident, tampering, or substitution of non-Graco component parts. Nor shall Graco be liable for malfunction, damage or wear caused by the incompatibility of Graco equipment with structures, accessories, equipment or materials not supplied by Graco, or the improper design, manufacture, installation, operation or maintenance of structures, accessories, equipment or materials not supplied by Graco.

This warranty is conditioned upon the prepaid return of the equipment claimed to be defective to an authorized Graco distributor for verification of the claimed defect. If the claimed defect is verified, Graco will repair or replace free of charge any defective parts. The equipment will be returned to the original purchaser transportation prepaid. If inspection of the equipment does not disclose any defect in material or workmanship, repairs will be made at a reasonable charge, which charges may include the costs of parts, labor, and transportation.

**THIS WARRANTY IS EXCLUSIVE, AND IS IN LIEU OF ANY OTHER WARRANTIES, EXPRESS OR IMPLIED, INCLUDING BUT NOT LIMITED TO WARRANTY OF MERCHANTABILITY OR WARRANTY OF FITNESS FOR A PARTICULAR PURPOSE.**

Graco's sole obligation and buyer's sole remedy for any breach of warranty shall be as set forth above. The buyer agrees that no other remedy (including, but not limited to, incidental or consequential damages for lost profits, lost sales, injury to person or property, or any other incidental or consequential loss) shall be available. Any action for breach of warranty must be brought within two (2) years of the date of sale.

**GRACO MAKES NO WARRANTY, AND DISCLAIMS ALL IMPLIED WARRANTIES OF MERCHANTABILITY AND FITNESS FOR A PARTICULAR PURPOSE, IN CONNECTION WITH ACCESSORIES, EQUIPMENT, MATERIALS OR COMPONENTS SOLD BUT NOT MANUFACTURED BY GRACO.** These items sold, but not manufactured by Graco (such as electric motors, switches, hose, etc.), are subject to the warranty, if any, of their manufacturer. Graco will provide purchaser with reasonable assistance in making any claim for breach of these warranties.

In no event will Graco be liable for indirect, incidental, special or consequential damages resulting from Graco supplying equipment hereunder, or the furnishing, performance, or use of any products or other goods sold hereto, whether due to a breach of contract, breach of warranty, the negligence of Graco, or otherwise.

## **FOR GRACO CANADA CUSTOMERS**

The Parties acknowledge that they have required that the present document, as well as all documents, notices and legal proceedings entered into, given or instituted pursuant hereto or relating directly or indirectly hereto, be drawn up in English. Les parties reconnaissent avoir convenu que la rédaction du présente document sera en Anglais, ainsi que tous documents, avis et procédures judiciaires exécutés, donnés ou intentés, à la suite de ou en rapport, directement ou indirectement, avec les procédures concernées.

# Graco Information

For the latest information about Graco products, visit [www.graco.com](http://www.graco.com).

For patent information, see [www.graco.com/patents](http://www.graco.com/patents).

**TO PLACE AN ORDER**, contact your Graco distributor or call 1-800-690-2894 to identify the nearest distributor.

*All written and visual data contained in this document reflects the latest product information available at the time of publication.  
Graco reserves the right to make changes at any time without notice.*

Original instructions. This manual contains English. MM 3A6417

**Graco Headquarters:** Minneapolis

**International Offices:** Belgium, China, Japan, Korea

**GRACO INC. AND SUBSIDIARIES • P.O. BOX 1441 • MINNEAPOLIS MN 55440-1441 • USA**  
**Copyright 2018, Graco Inc. All Graco manufacturing locations are registered to ISO 9001.**

[www.graco.com](http://www.graco.com)  
Revision L, September 2025